

# DFSCP12

## Flat Surface Cleaner



### SPECIFICATIONS

Part Number	DFSCP12
Operating Pressure	1,500 - 3,500 PSI
Max Flow	6.0 GPM
Dimensions	12.7" x 5.8"
Weight	4.0 lbs

### FEATURES / BENEFITS

- Full 12" cleaning path
- Can be connected directly to gun, lance, telescoping wand
- Lightweight, anodized aluminum components
- Durable polypropylene deck and handle
- Includes 1/4" quick disconnect plug

**WARNING: Read Before Operating Machine**  
 Always wear protective eyewear  
 Keep clear of rotating nozzles  
 Never lock trigger gun open with any device  
 Drain water in cold weather to avoid freezing  
 Tampering with any part of this machine will void all warranties

### PARTS LIST

NO.	PART NO.	DESCRIPTION	QTY.
1	2660193	Deck, 12"	1
2	2103076	Swivel, FSC, 12"	1
3	2660195	Assy, Brush	1
4	2630001	Plate, Retaining	1
5	2200017	Bolt, M6 x 14	4
6	2660194	Handle	1
7	2200006	Screw	2
8	2203407	Washer	2
		<b>Repair Kits</b>	
	2100292	Swivel Repair Kit	
	2660195	Brush Replacement Kit	

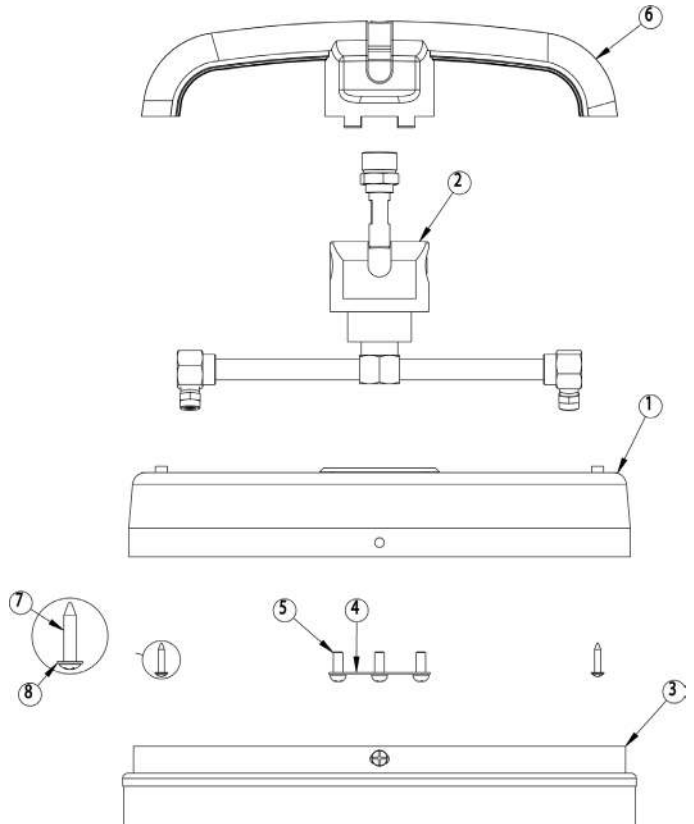

### PARTS LIST

NO.	PART NO.	DESCRIPTION	QTY.
1	2500006	Housing, Swivel	1
2	2510195	Swivel, Inlet	1
3	2550124	Tube, Inlet	1
4	2103077	Assy, Arm, 12"	1
5	2640018	Bearing, Ball	1
6	2520103	Stem, Upper	1
7	2820007	Spring	1
8	D10022	Fitting, M22	1
9	2510196	<b>Plug, Pipe, 1/4 NPT</b>	1
10	2202020	Snap Ring	1
11	2202019	Snap Ring	1
12	2520105	Stem, Lower	1
13	2701056	O-ring	2
14	2701057	O-ring	2
15	2710023	Back-up Ring	2
16	2710024	Back-up Ring	2
17	2103078	Nozzle	2

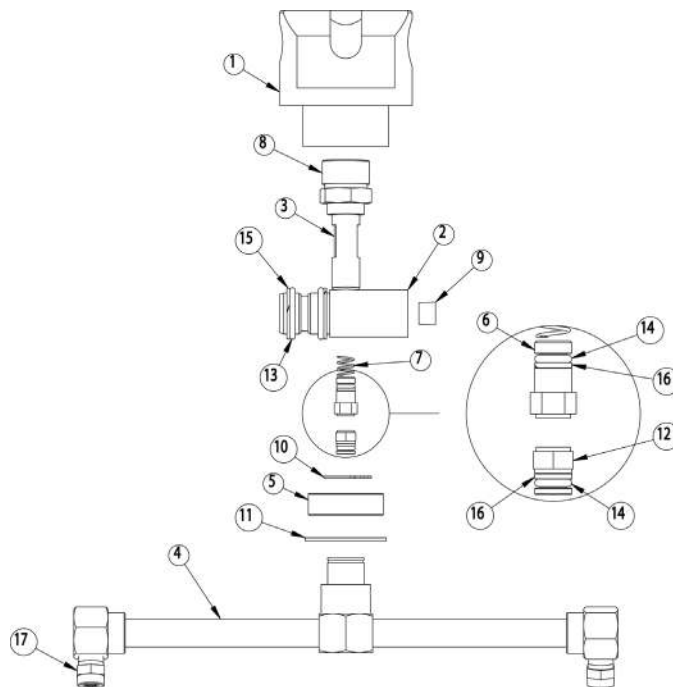

### ASSEMBLY / OPERATING INSTRUCTIONS

1. Connect directly to gun, lance or telescoping wand.
2. Turn water on and open trigger gun for flow of water through nozzles. Nozzles must have flowing spray. If not, remove tips and clean; reassemble, making sure nozzle groove is parallel to spray bar. Use thread sealant when installing nozzles.
3. Start pressure Washer. The flat surface cleaner is ready for operation.
4. Move the flat surface cleaner slowly across surface. If striping occurs, slow down your pace.
5. Periodically check weep hole on bottom of swivel. Water may seep slowly; if water sprays out, stop and replace swivel.
6. For maximum effectiveness keep spray tips clean. If the machine vibrates, stop and clean spray tips.

**DO NOT ALLOW MACHINE TO REMAIN STATIONARY  
ON SOFT SURFACES SUCH AS WOOD.**

Caution: Striking any raised obstacle during operation will damage machine. If contact does occur and results in vibration when operating machine, STOP and replace spray bar. Continued operation could result in serious injury or damage to machine.



**WARNING:** This product can expose you to chemicals, including lead, which is known to the state of California to cause cancer and birth defects or other reproductive harm. For more information, go to [www.P65Warnings.ca.gov](http://www.P65Warnings.ca.gov) Made in China