



ENGLISH



Models:
35, 55-1, 55-2, 75-1, 75-2

MAXXI II

Service Manual

Nilfisk
ALTO
works for you

Preface	3
Safety Issues	4
Technical specifications	5
Construction	10
Top	10
Container	13
Parts	15
Models:	
35	15
55-1, 75-1	17
55-2, 75-2	18
55, 75 BSF, BDF	19
Filter and Bags	20
Squeegee	20
Diagrams	21
Notes	22

In this manual you will find the essentials you need to know when repairing the wet and dry vacuum cleaners in the MAXXI II series. When carrying out repairs, make sure you have a suitable workbench or the like with the necessary water and power supply available.

- If you determine an error in operation, be sure to refer the customer to the user manual.

A fault in the equipment can have a number of causes. The chapter "service / repair" will help you here. Use the illustrated spare parts lists for your repairs. These show you the location of the individual parts and the sequence in which they are assembled.

- Always refer to the technical service bulletin information sheets. Also known as TSB's

These will tell you about any technical modifications made after publication of this service manual.

- Only use **original Nilfisk-ALTO** spare parts

It is under no circumstances legal to provide this service manual and any technical service bulletin that might be released to third party without a written approval from the Global Product Management group, located at

Sognevej 25, 2605 Brøndby, Denmark

**To be performed by a skilled or instructed person only !
Disconnect the vacuum cleaner from the power supply before
starting the work!**



Safety instructions marked with this symbol in this manual must be observed to prevent danger to persons.

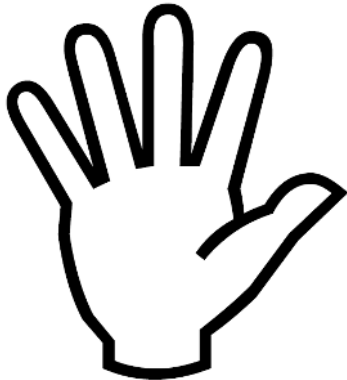

This symbol is used to mark safety instructions that must be observed to prevent damage to the equipment and degradation of performance.



This symbol indicates tips and instructions to simplify work and to ensure safe operation.

Technical description				
MAXXI II Series				
Service data	Unit	Europe		
Model		MAXXI II	MAXXI II	MAXXI II
Country Variants		EU	EU	EU
Technical Data ↓				
Electric:				
Power Picc	W	1250	1250 / 2400	1250 / 2400
Max Power	W	1350	1350 / 2500	1350 / 2500
IP Protection		IP24	IP24	IP24
Plug style		EU	EU	EU
Cable length	m	10	10	10
Motor:				
Numbers of motors		1	1 / 2	1 / 2
Suction power	W	250	250 / 390	250 / 390
Vacuum	mbar / kPa	200 / 20	200 / 20 - 210 / 21	200 / 20 - 210 / 21
Air flow	l/min	2880	2880 / 4320	2880 / 4320
Unit Data:				
Container size	l	35	55	75
Container net filling - dry (without bag)	l	35	51,7	71,2
Container net filling - dry (with bag)	l	18,2	28,1	44,4
Container net filling (wet)	l	24.5	38.5	52.5
Container material		PPC	PPC	PPC
Wet filter area	cm ²	1051	1840	1840
Cartridge filter area	cm ²	2070	4410	4410
Hose length	m	1.9	2.5	2.5
Accessories diameter	mm	32	40	40
Sound pressure IEC 704	dB	81	82 / 84	82 / 84
Sound pressure BS 5415	dB	62	64 / 66	64 / 66
Weight	kg	12,5	24,5 / 25,5	27 / 28
Dimensions	cm	46,2x42x73,6	84,2x62x100	84,2x62x100
Drain hose		No	Yes	Yes

Technical specification for the MAXXI II EU variants

Technical description				
MAXXI II Series				
Service data	Unit	United Kingdom		
Model		MAXXI II	MAXXI II	MAXXI II
Country Variants		UK	UK	UK
Technical Data ↓				
Electric:				
Power Picc	W	1250	1250 / 2400	1250 / 2400
Max Power	W	1350	1350 / 2500	1350 / 2500
IP Protection		IP24	IP24	IP24
Plug style		UK	UK	UK
Cable length	m	10	10	10
Motor:				
Numbers of motors		1	1 / 2	1 / 2
Suction power	W	250	250 / 390	250 / 390
Vacuum	mbar / kPa	200 / 20	200 / 20 - 210 / 21	200 / 20 - 210 / 21
Air flow	l/min	2880	2880 / 4320	2880 / 4320
Unit Data:				
Container size	l	35	55	75
Container net filling - dry (without bag)	l	35	51,7	71,2
Container net filling - dry (with bag)	l	18,2	28,1	44,4
Container net filling (wet)	l	24.5	38.5	52.5
Container material		PPC	PPC	PPC
Wet filter area	cm ²	1051	1840	1840
Cartridge filter area	cm ²	2070	4410	4410
Hose length	m	1.9	2.5	2.5
Accessories diameter	mm	32	40	40
Sound pressure IEC 704	dB	81	82 / 84	82 / 84
Sound pressure BS 5415	dB	62	64 / 66	64 / 66
Weight	kg	12,5	24,5 / 25,5	27 / 28
Dimensions	cm	46,2x42x73,6	84,2x62x100	84,2x62x100
Drain hose		No	Yes	Yes

Technical specification for the MAXXI II UK variants

Technical description				
MAXXI II Series				
Service data	Unit	Australia / New Zealand		
Model		MAXXI II	MAXXI II	MAXXI II
Country Variants		AU / NZ	AU / NZ	AU / NZ
Technical Data ↓				
Electric:				
Power Pic	W	1250	1250 / 2400	1250 / 2400
Max Power	W	1350	1350 / 2500	1350 / 2500
IP Protection		IP24	IP24	IP24
Plug style		AU / NZ	AU / NZ	AU / NZ
Cable length	m	10	10	10
Motor:				
Numbers of motors		1	1 / 2	1 / 2
Suction power	W	250	250 / 390	250 / 390
Vacuum	mbar / kPa	200 / 20	200 / 20 - 210 / 21	200 / 20 - 210 / 21
Air flow	l/min	2880	2880 / 4320	2880 / 4320
Unit Data:				
Container size	l	35	55	75
Container net filling - dry (without bag)	l	35	51,7	71,2
Container net filling - dry (with bag)	l	18,2	28,1	44,4
Container net filling (wet)	l	24.5	38.5	52.5
Container material		PPC	PPC	PPC
Wet filter area	cm ²	1051	1840	1840
Cartridge filter area	cm ²	2070	4410	4410
Hose length	m	1.9	2.5	2.5
Accessories diameter	mm	32	40	40
Sound pressure IEC 704	dB	81	82 / 84	82 / 84
Sound pressure BS 5415	dB	62	64 / 66	64 / 66
Weight	kg	12,5	24,5 / 25,5	27 / 28
Dimensions	cm	46,2x42x73,6	84,2x62x100	84,2x62x100
Drain hose		No	Yes	Yes

Technical specification for the MAXXI II AU / NZ variants

Technical description				
MAXXI II Series				
Service data	Unit	United States		
Model		MAXXI II	MAXXI II	MAXXI II
Country Variants		US	US	US
Technical Data ↓				
Electric:				
Power Pic	W	1000	1000 / 1840	1000 / 1840
Max Power	W	1100	1100 / 2000	1100 / 2000
IP Protection		IP24	IP24	IP24
Plug style		US	US	US
Cable length	m	15	15	15
Motor:				
Numbers of motors		1	1 / 2	1 / 2
Suction power	W	220	170 / 340	170 / 340
Vacuum	mbar / kPa	200 / 20	180 / 18 - 190 / 19	180 / 18 - 190 / 19
Air flow	l/min	2700	2400 / 3840	2400 / 3840
Unit Data:				
Container size	l	35	55	75
Container net filling - dry (without bag)	l	35	51,7	71,2
Container net filling - dry (with bag)	l	18,2	28,1	44,4
Container net filling (wet)	l	24.5	38.5	52.5
Container material		PPC	PPC	PPC
Wet filter area	cm ²	1051	1840	1840
Cartridge filter area	cm ²	2070	4410	4410
Hose length	m	1.9	2.5	2.5
Accessories diameter	mm	32	40	40
Sound pressure IEC 704	dB	81	82 / 84	82 / 84
Sound pressure BS 5415	dB	62	64 / 66	64 / 66
Weight	kg	12,5	24,5 / 25,5	27 / 28
Dimensions	cm	46,2x42x73,6	84,2x62x100	84,2x62x100
Drain hose		No	Yes	Yes

Technical specification for the MAXXI II US variants

Technical description				
MAXXI II Series				
Service data	Unit	Japan		
Model		MAXXI II	MAXXI II	MAXXI II
Country Variants		JP	JP	JP
Technical Data ↓				
Electric:				
Power Picc	W	1150	1150	1150
Max Power	W	1250	1250	1250
IP Protection		IP24	IP24	IP24
Plug type		JP	JP	JP
Cable length	m	15	15	15
Motor:				
Numbers of motors		1	1	1
Suction power	W	250	200	200
Vacuum	mbar / kPa	200 / 20	180 / 18	180 / 18
Air flow	l/min	2880	2520	2520
Unit Data:				
Container size	l	35	55	75
Container net filling - dry (without bag)	l	35	51,7	71,2
Container net filling - dry (with bag)	l	18,2	28,1	44,4
Container net filling (wet)	l	24.5	38.5	52.5
Container material		PPC	PPC	PPC
Wet filter area	cm ²	1051	1840	1840
Cartridge filter area	cm ²	2070	4410	4410
Hose length	m	1.9	2.5	2.5
Accessories diameter	mm	32	40	40
Sound pressure IEC 704	dB	81	82	82
Sound pressure BS 5415	dB	62	64	64
Weight	kg	12,5	24,5 / 25,5	27 / 28
Dimensions	cm	46,2x42x73,6	84,2x62x100	84,2x62x100
Drain hose		No	Yes	Yes

Technical specification for the MAXXI II JP variants

MAXXI II - Top 35

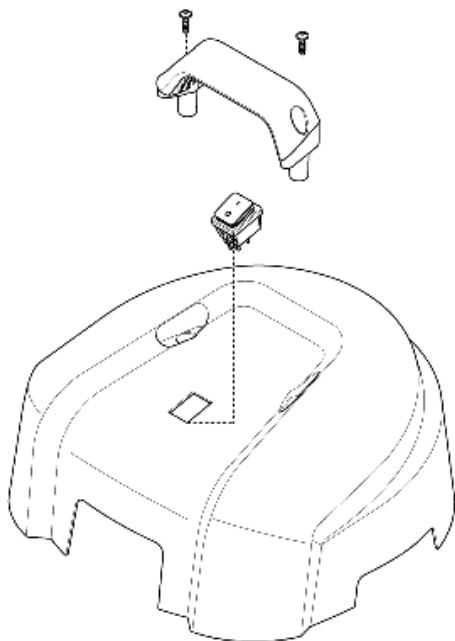

Art: 6.1

Art: 6.1 shows how the handle, top cover and the switch is placed on top of the motor cover.

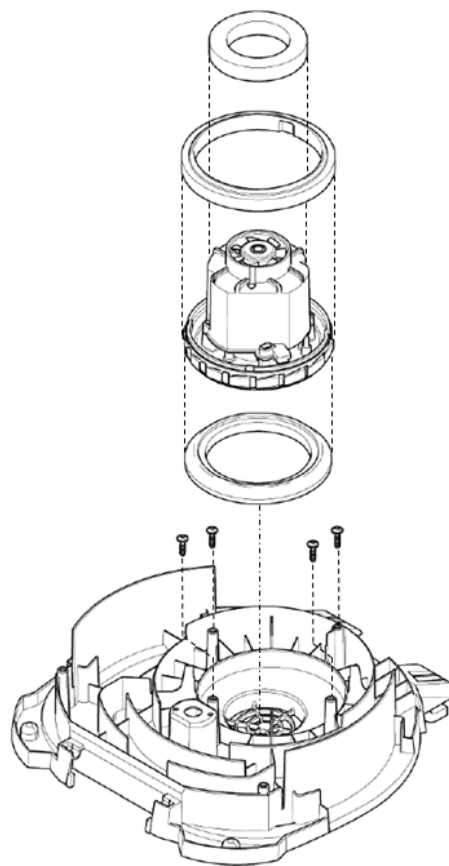

Art: 6.3

Art: 6.3 shows how the motor is fitted into the bottom part of the motor head.

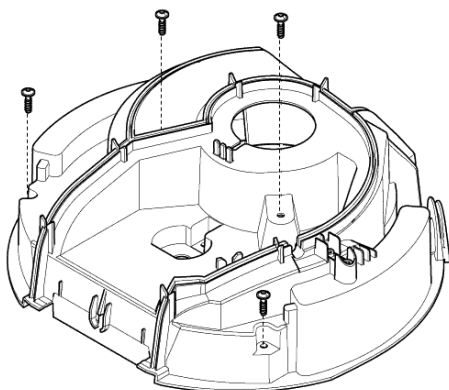

Art: 6.2

Art: 6.2 shows how the motor cover is fitted into the bottom part of the motor head.

Please refer to the spare part list for part numbers.

MAXXI II - Top 55-1, 75-1

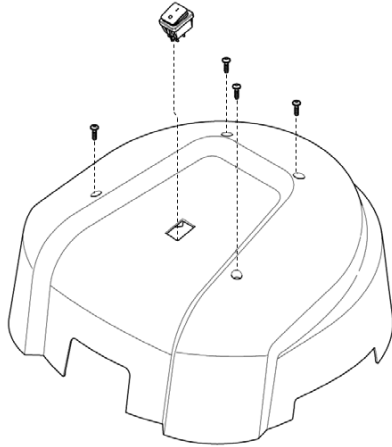

Art: 7.1

Art: 7.1 shows how the top cover and the switch is placed on top of the motor cover.

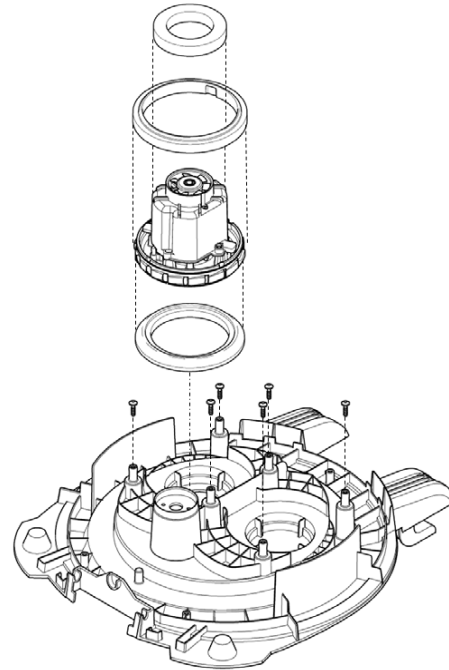

Art: 7.3

Art: 7.3 shows how the motor is fitted into the bottom part of the motor head.

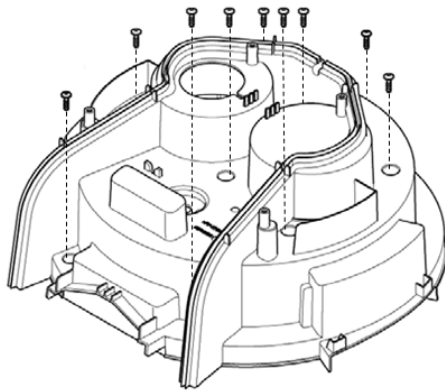

Art: 7.2

Art: 7.2 shows how the motor cover is fitted into the bottom part of the motor head.

Please refer to the spare part list for part numbers.

MAXXI II - Top 55-2, 75-2

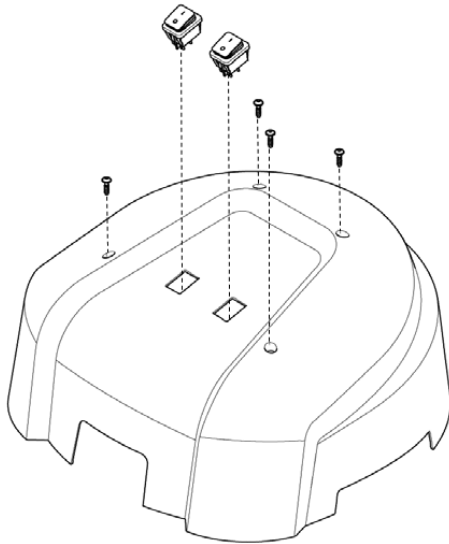

Art: 8.1

Art: 8.1 shows how the top cover and the switches are placed on top of the motor cover.

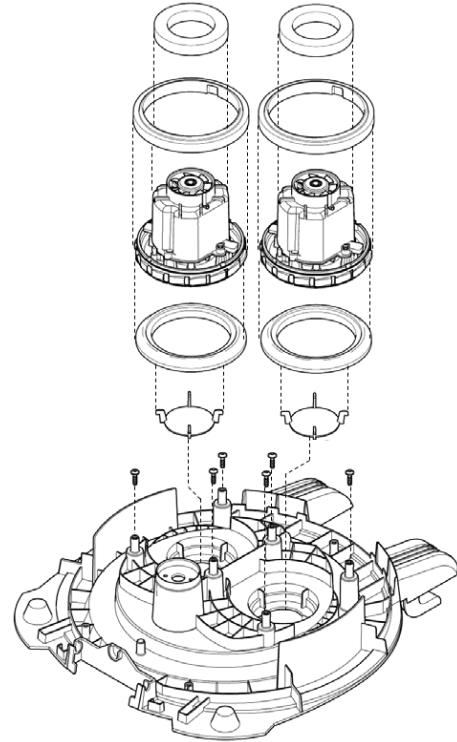

Art: 8.3

Art: 8.3 shows how the motors are fitted into the bottom part of the motor head.

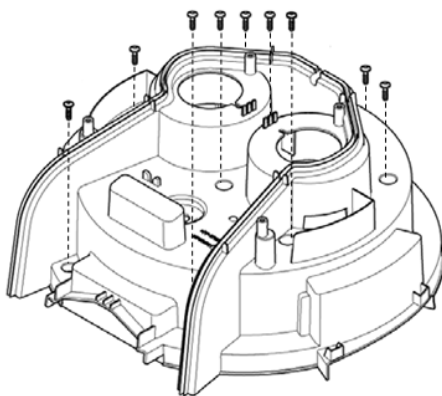

Art: 8.2

Art: 8.2 shows how the motor cover is fitted into the bottom part of the motor head.

Please refer to the spare part list for part numbers.

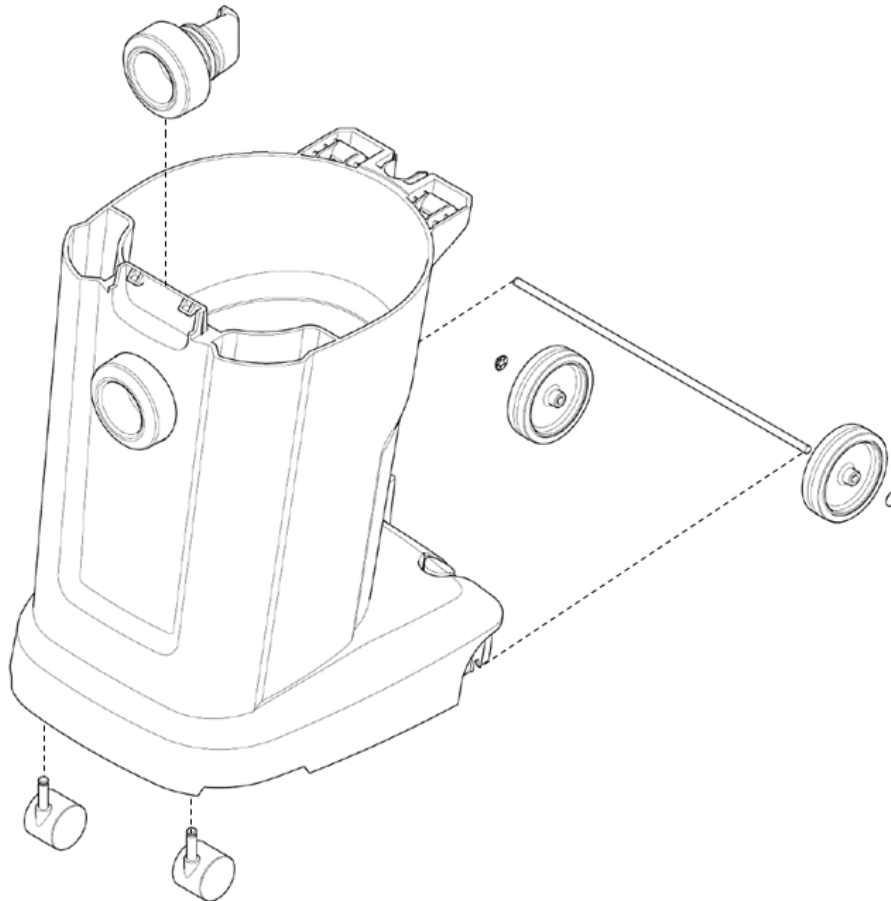
MAXXI II - Container 35

Art: 9.1

Art: 9.1 shows how the 35 L container is fitted with front and back wheels including the rear axel.

*Please note that the inlet will need to be damaged/cut in order to change it.

Please refer to the spare part list for part numbers.

MAXXI II - Container 55-1, 55-2, 75-1, 75-2

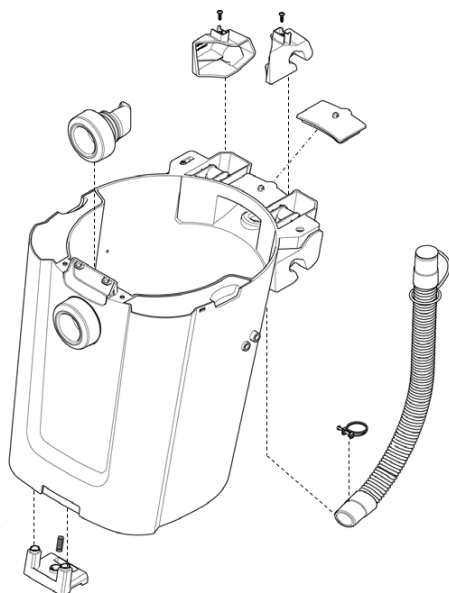

Art: 10.1

Art: 10.1 shows how the drain hose, drain lid, and the release is fitted to the container.

*Please note that the Inlet will need to be damaged/cut in order to change it.

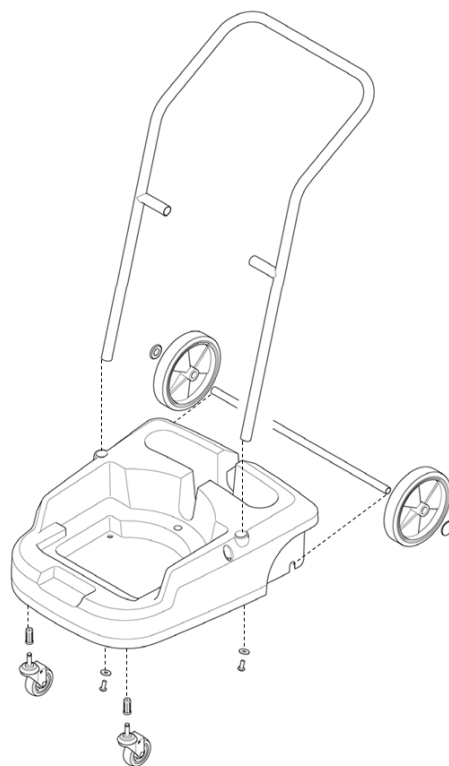

Art: 10.2

Art: 10.2 shows how the front- and rear wheels, axel, and the handle is fitted to the trolley.

Please refer to the spare part list for part numbers.

MAXXI II - Top 35

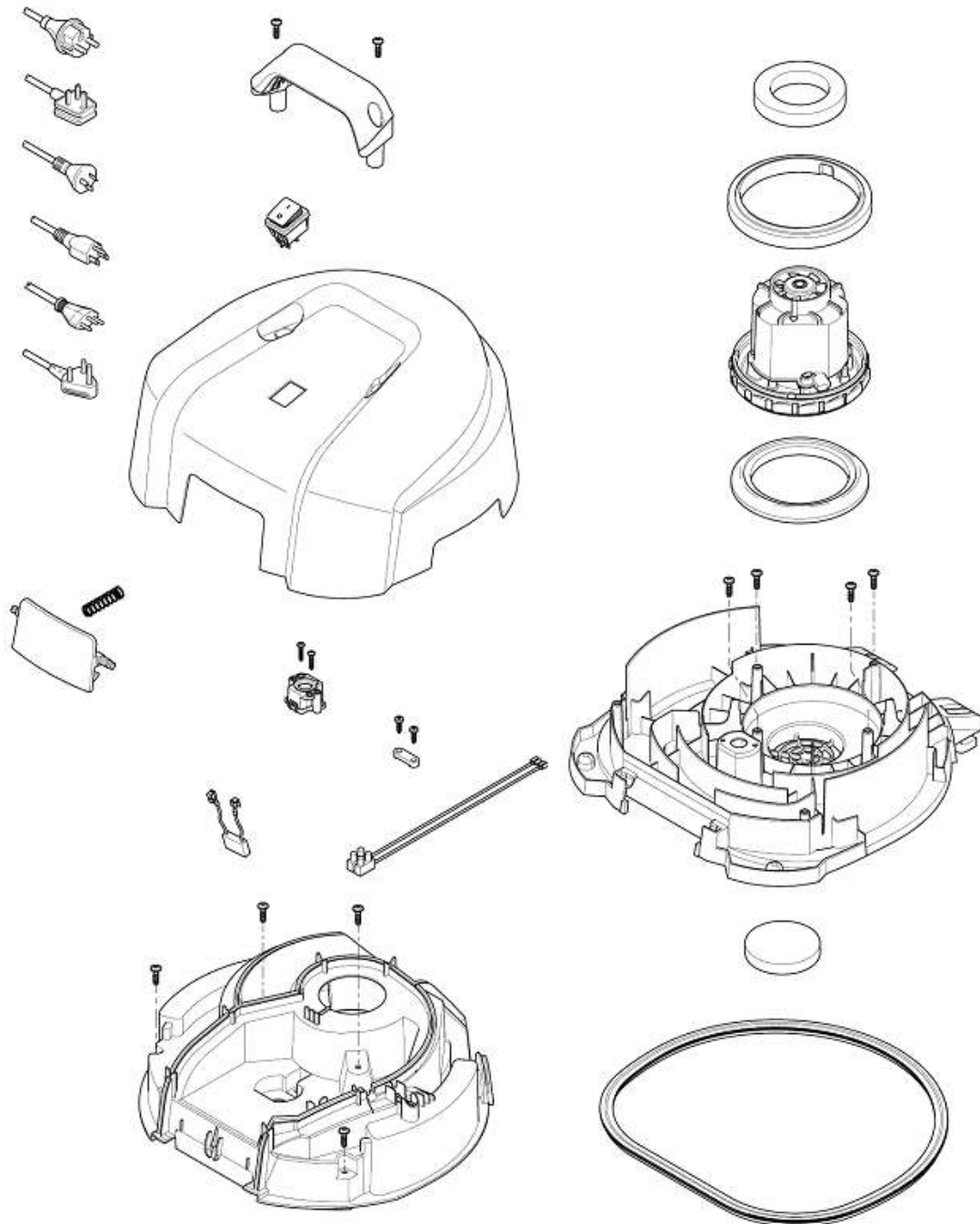

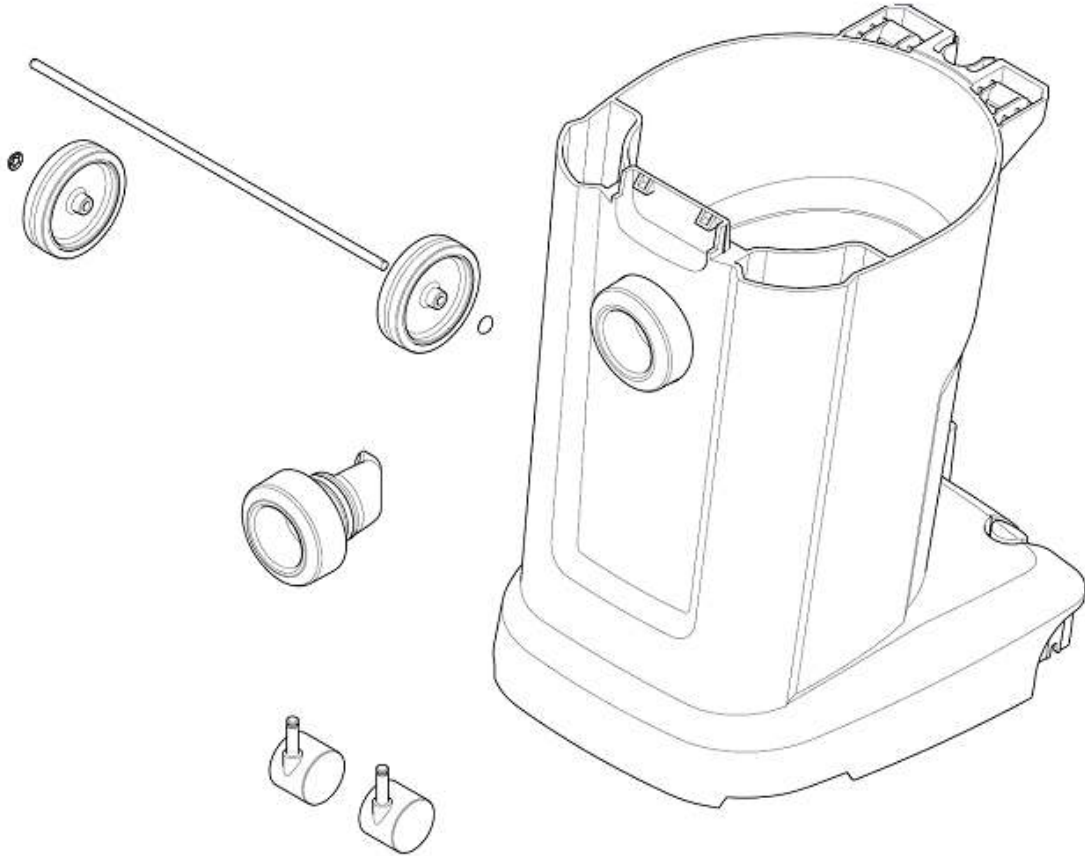
MAXXI II - Container 35

MAXXI II - Top 55-1, 75-1

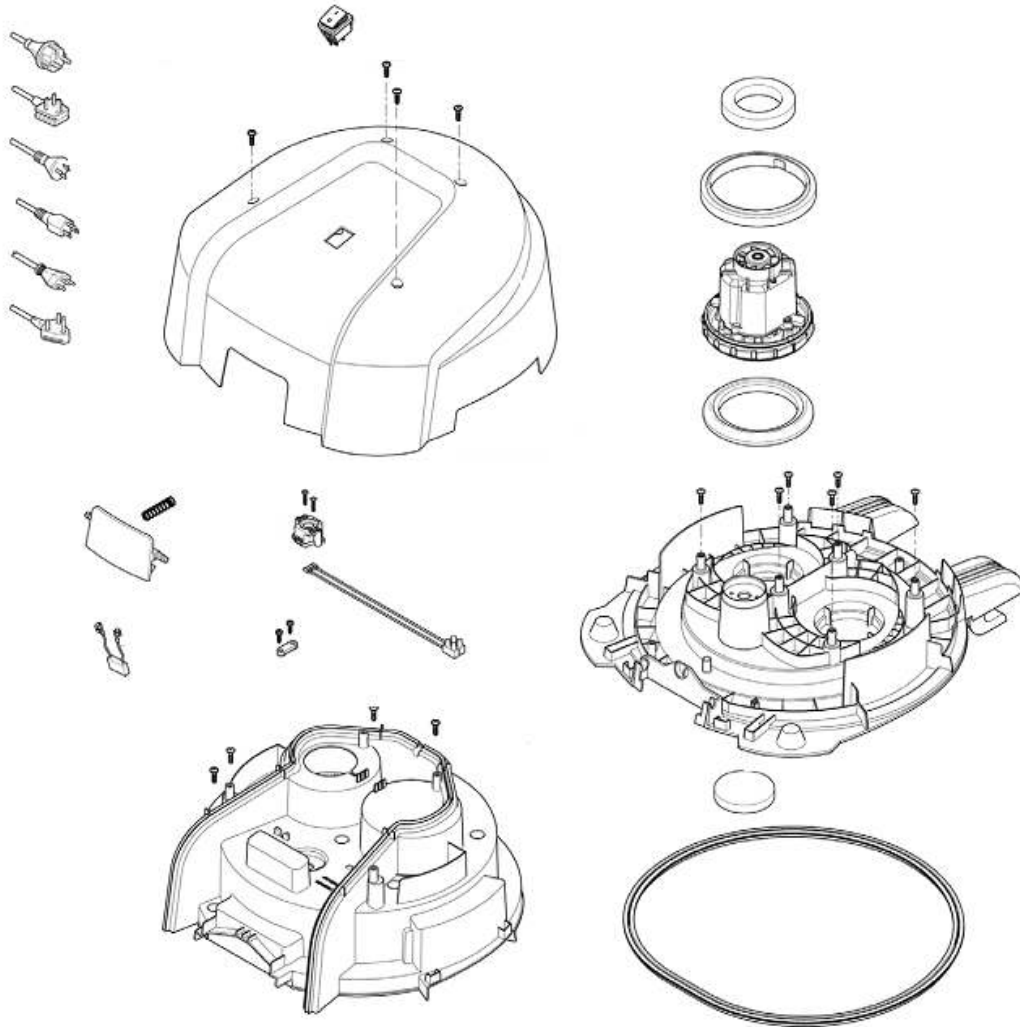

MAXXI II - Top 55-2, 75-2

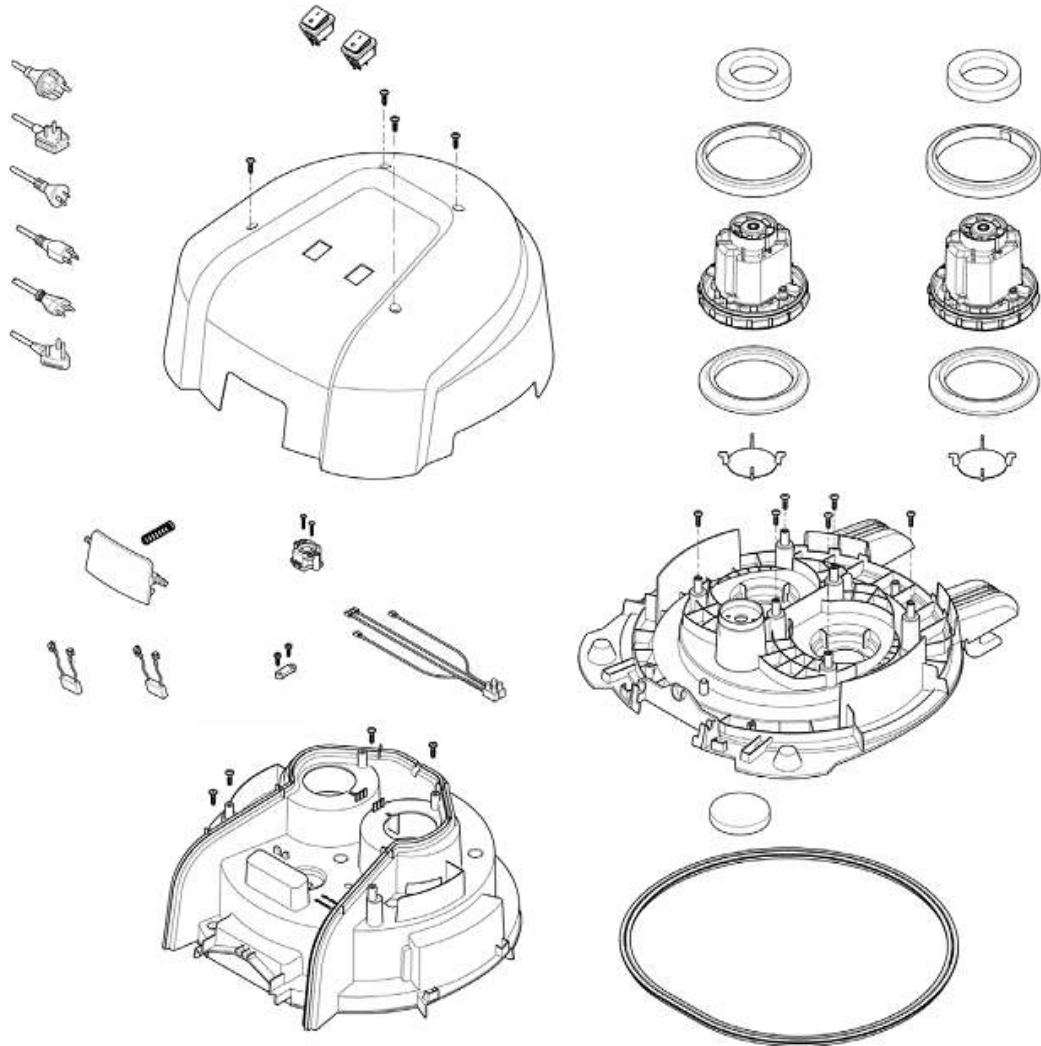

MAXXI II - Container 55, 75 BSF, BDF

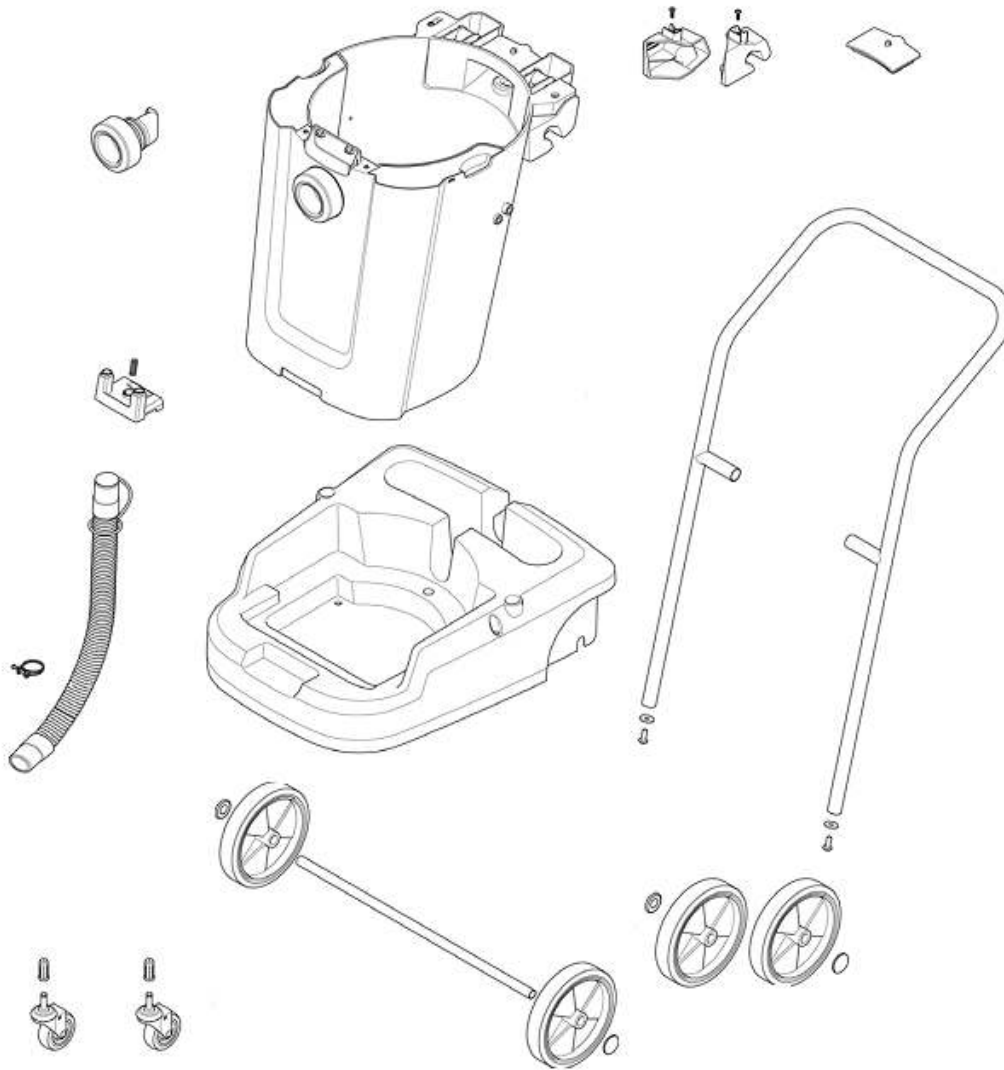

MAXXI II - Filter and Bags

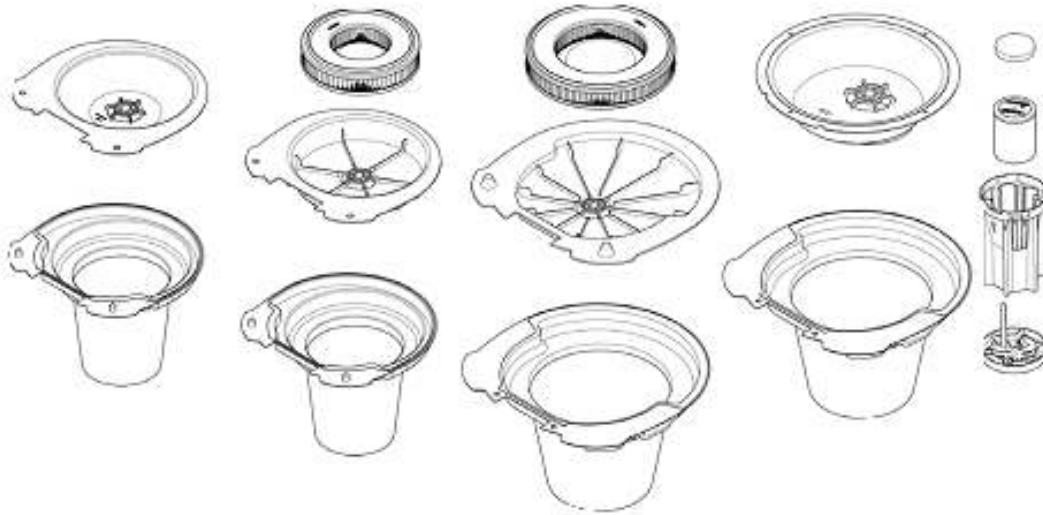

MAXXI II - Squeegee

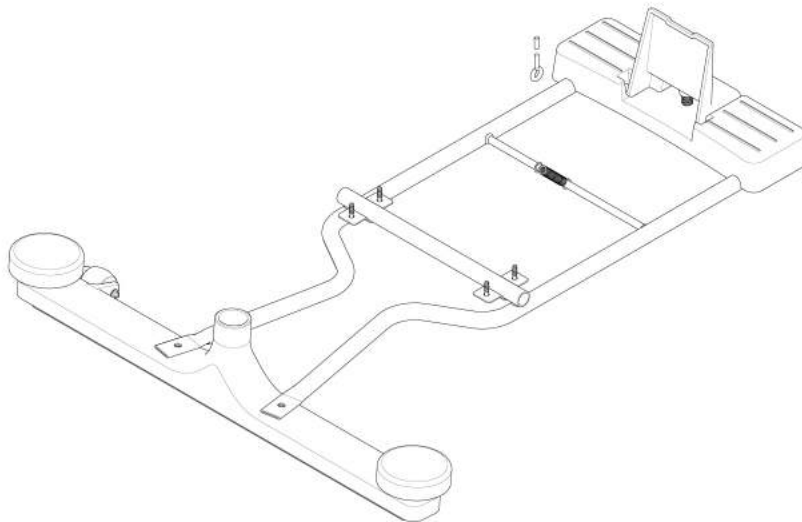

Electrical diagram for 1 motor

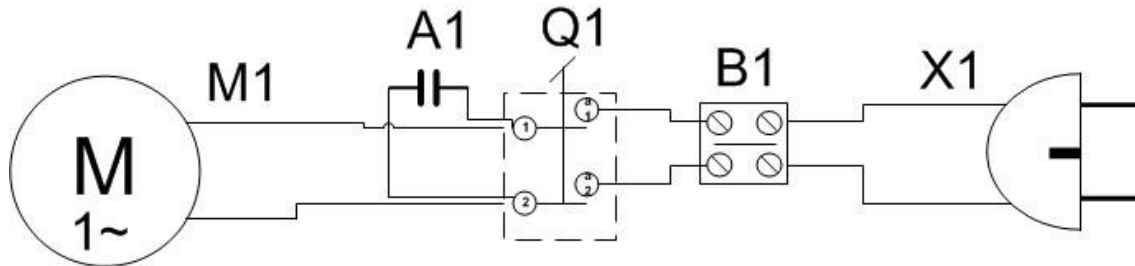

- M1 Motor turbine
- A1 Capacitor
- Q1 Main switch
- B1 Terminal block
- X1 Power cord

Electrical diagram for 2 motor

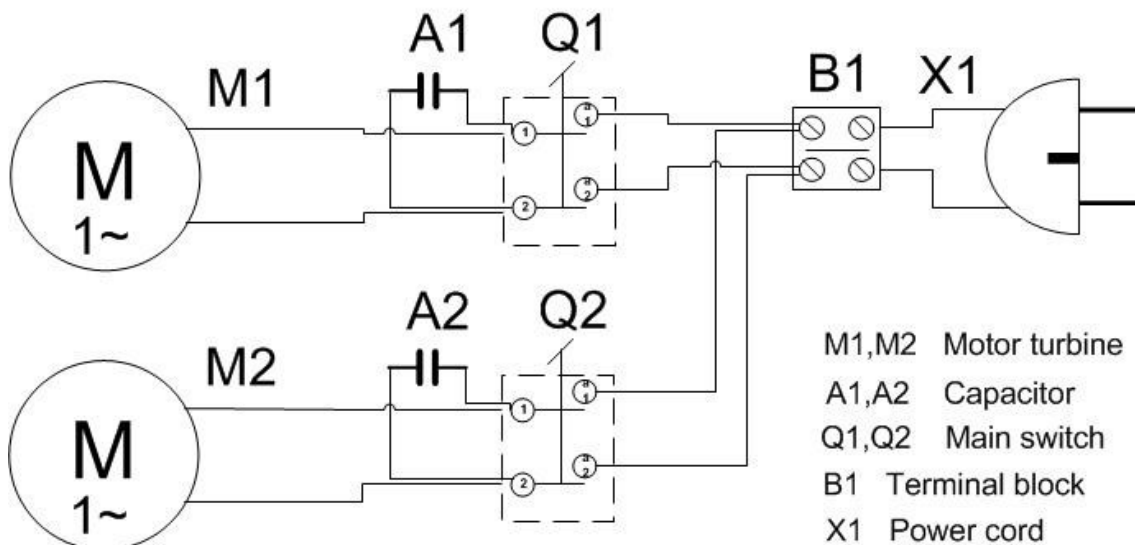

- M1,M2 Motor turbine
- A1,A2 Capacitor
- Q1,Q2 Main switch
- B1 Terminal block
- X1 Power cord

