

DHRA50150/300/450

Industrial Hose Reels



SPECIFICATIONS

PART NUMBER	DHRA50150	DHRA50300	DHRA50450
3/8" Hose Capacity	150 ft.	300 ft.	450 ft.
5/8" Garden Hose Cap.	125 ft.	225 ft.	325 ft.
3/4" Garden Hose Cap.	100 ft.	175 ft.	250 ft.
Swivel Pressure Rating	5,000 PSI		
Inlet	1/2" NPT-F		
Outlet	1/2" NPT-F		
Max. Temp	250° F		

FEATURES / BENEFITS

- Friction Brake
- Direct hand-crank rewind with folding mechanism and drum locking pin
- Solid steel construction
- Durable powdercoated finish
- Full flow swivel stainless swivel with internal bearing

DIMENSIONS

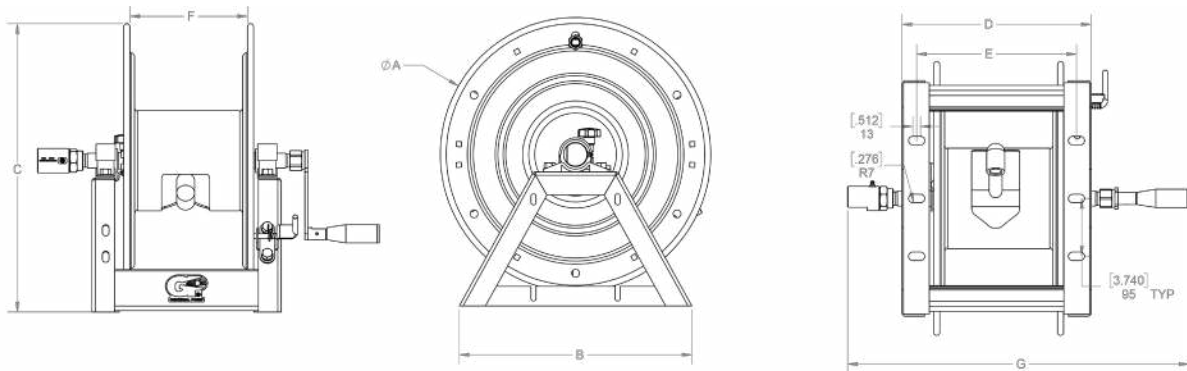

	Dimensions inches/mm						
	A	B	C	D	E	F	G
DHRA50150	17.7/449	15.2/387	18.6/473	12.4/315	10.4/264	7.4/189	22.4/568
DHRA50300	17.7/449	15.2/387	18.6/473	17.5/445	15.5/394	12.5/319	27.5/699
DHRA50450	17.7/449	15.2/387	18.6/473	23.0/585	21.2/539	18.1/459	33.0/839

PARTS LIST

PARTS LIST

Item	Part No.	Description	QTY
1	2103321	Assy, Hub & Flange, DHRA50450	1
	2103319	Assy, Hub & Flange, DHRA50300	
	2103317	Assy, Hub & Flange, DHRA50150	
2	2103322	Frame, Hose Reel, DHRA50450	1
	2103320	Frame, Hose Reel, DHRA50300	
	2103318	Frame, Hose Reel, DHRA50150	
3	2203413	Washer, Flat, M10	12
4	2203017	Nut, M10 , NYLOK, SST	6
5	2200104	Bolt, M10	6
6	2400004	Decal, GP	1
Replacement Parts Below			
7	2640025	Pillow Block	2
8	2103312	Assy., Crank Folding	1
9	2103245	Assy., Pin Lock	1
10	2103139	Brake Kit	1
11	2540087	Bracket, Brake	1
12	DSW9012SS	Swivel, 1/2" NPT-F, Ball Bearing	1
13	2530112	Fitting, 1/2 NPT-M x 3/8 NPT-F	2

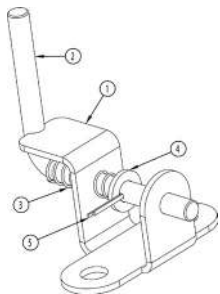
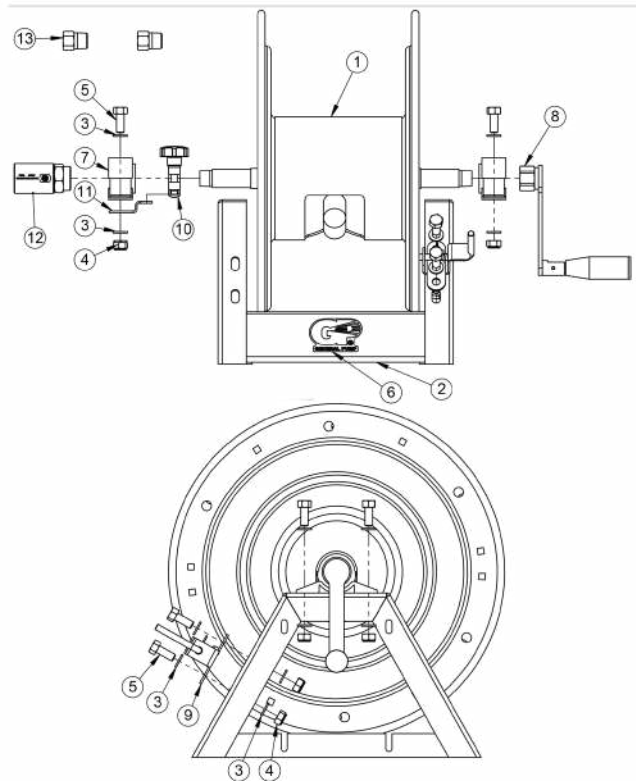

Lock Pin Repair Kit 2103245			
Item	Part No.	Description	QTY.
1	2540085	Bracket, Lock	1
2	2540086	Pin, Lock	1
3	2720025	Spring, Lock Pin	1
4	2200013	Washer, M8, SS	1
5	2202033	Pin, Cotter, 2x20	1

Brake Repair Kit 2103139			
Item	Part No.	Description	QTY.
1	2660268	Brake	1
2	2200103	Bolt, M8	1
3	2660405	Knob, Brake	1
4	2200013	Washer, M8, SS	1

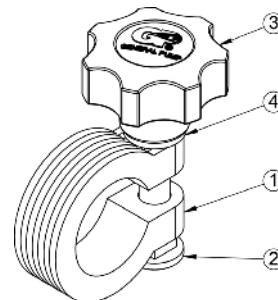

ASSEMBLY / OPERATING INSTRUCTIONS

1. Connect the handle to either end of the axle which doubles as a fluid path, use a suitable thread sealant and tighten accordingly.
2. Connect the swivel on the opposite end of the axle as the handle, use a suitable thread sealant and tighten accordingly.
* See parts list image for orientation of swivel*
3. Attach outlet hose to the outlet fitting located in the hub, use a suitable thread sealant and tighten accordingly.
4. Attach supply hose to the hose reel swivel, use a suitable thread sealant and tighten accordingly.
5. Use 1/2" or 13 mm bolts when securing the hose reel to ceiling or wall.
6. The hose reel is ready for operation.

NOTE: THREAD SEALANT NOT INCLUDED

CAUTION: When using hardened NPT fittings DO NOT over tighten, over-tightening can result in a cracked swivel or fitting.

WARNING!

Exposure of skin directly to pressurized air or fluids could result in severe bodily injury!

Warning. Only trained and qualified personnel should install or replace the device.

Warning. De-pressurize prior to servicing.

OPTIONAL A-FRAME ACCESSORIES



Hose Reel Hose Guide

- DHRA50150/SS use part #2100462
- DHRA50300/SS use part #2100463
- DHRA50450 use part #2100503
- Protects hose when pulling out at an angle
- 4-way pinch-proof stainless steel guides

Hose Reel Stacking Kit

- Part #2100437
- Fits all DHRA hose reels
- Stacks up to 4 hose reels high
- Powder-coated steel construction

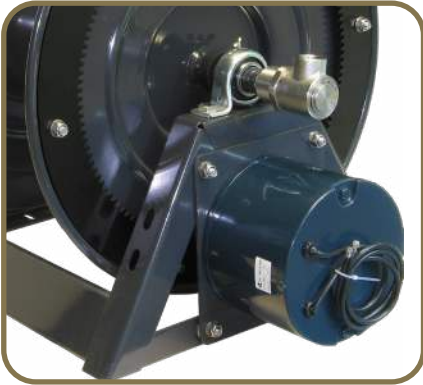

12 Volt DC Electric Hose Reel Motor Kit

- Part #2103410
- Fits all DHRA hose reels
- Allows for effortless rewinding of hose
- Free spin allows for easy pulling out of hose
- Stainless steel hardware

Hose Reel Cart

- Part #2100465
- Fits all DHRA hose reels
- Easy storage and movement
- Powder-coated steel frame
- Solid polyurethane wheels
- Also works with Stacking Kit 2100437



12 Volt DC Variable Speed Controller Rewind Kit

- Part #DMC12V
- Fits all DHRA hose reels with 12V motor
- 30 amp auto-reset circuit breaker
- Variable speed knob with built-in on/off function
- Reversible powder-coated mounting plate for left or right orientation
- Sealed housing