

**20 mm bore / 16 mm stroke**

**FEATURES**

- The preferred pump frame in the pressure cleaning industry
- Forged brass manifold with an exclusive lifetime warranty
- Large-capacity, die-cast, anodized aluminum oil-bath crankcase
- Over-sized connecting rods for maximum life
- Heavy-duty tapered roller bearing
- Solid ceramic plungers with continuously lubricated packings
- Unitized stainless steel inlet and discharge valves



**SPECIFICATIONS**

Pump Model	HP5535	
Maximum Volume (GPM)	4.5	5.6
Max. Discharge Pressure (PSI)	3500	3500
Maximum Pump Speed (RPM)	1125	1450
Maximum Inlet Pressure	125 PSI	
Maximum Inlet Vacuum	9 ft. water (7.9 in. Hg)	
Bore	.787 in. / 20 mm	
Stroke	.630 in. / 16 mm	
Crankcase Oil Capacity	40.6 oz.	
Maximum Fluid Temperature	165°F	
Inlet Port Thread	1/2-14 BSPP-F	
Discharge Port Thread	3/8-19 BSPP-F	
Shaft Diameter	.945 in. / 24 mm	
Weight	32 lbs.	
Dimensions	12.2 x 9.2 x 6.9 in.	

**DIMENSIONAL DRAWING**

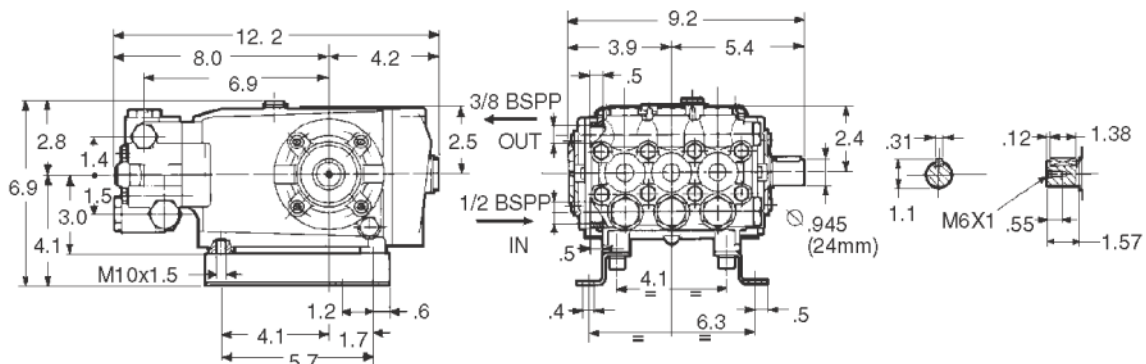



20 mm bore / 16 mm stroke

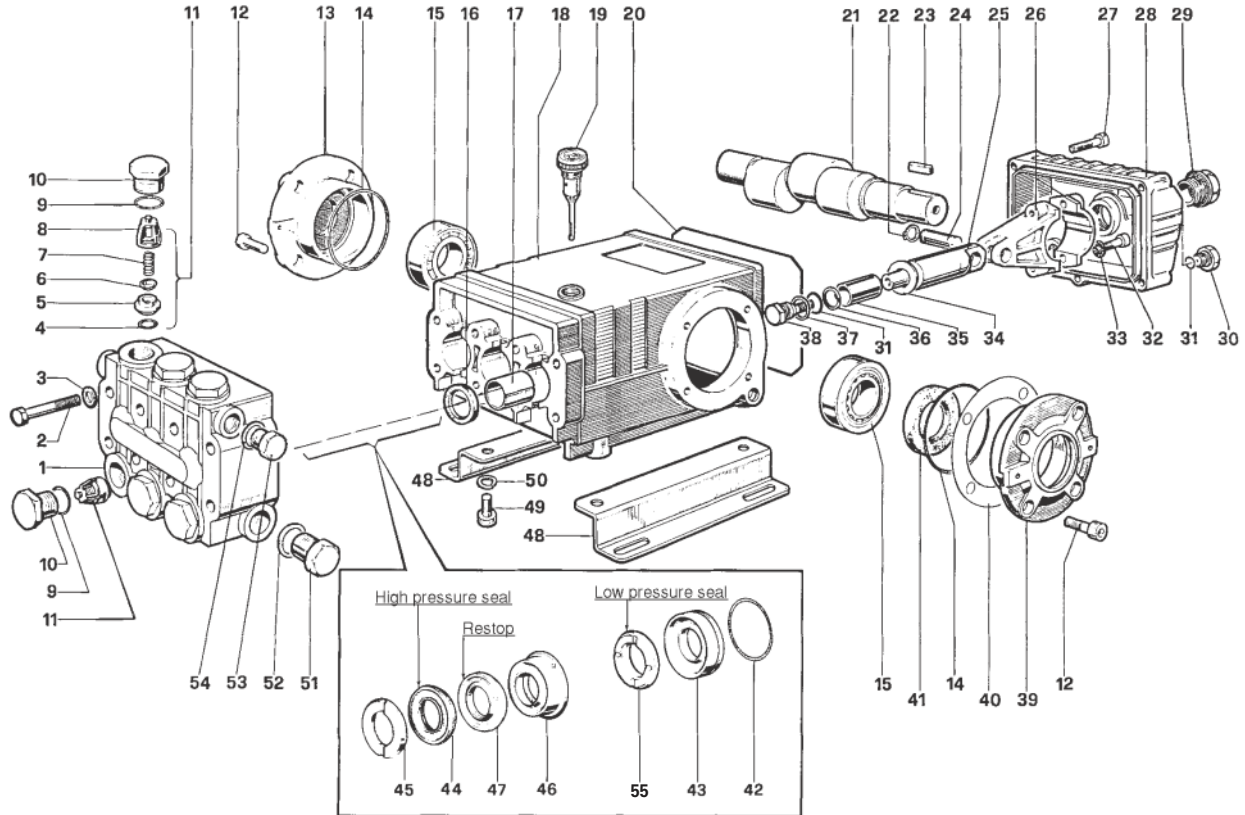

**PARTS LIST**

ITEM PART NO.	DESCRIPTION	KIT NO.	QTY.	ITEM PART NO.	DESCRIPTION	KIT NO.	QTY.	ITEM PART NO.	DESCRIPTION	KIT NO.	QTY.
1	47120841	Manifold	1	20	90392200	O-Ring, Cover	1	39	47150022	Cover, Crankcase	1
2	99320600	Screw, M8 x 70	8	21	47021735	Crankshaft	1	40	97567800	Shim	2
3	96702000	Washer, M8.4	8	22	90055700	Ring, Snap	6	41	90164800	Seal, Oil	3
4	90384100	O-Ring, .674 x .103	1	23	91489000	Key	1	42	90361600	O-Ring, 1.364 x .070	10, 28
5	36200366	Seat, Valve	1	24	97738000	Pin, Wrist	3	43	47080570	Retainer, Packing	10, 28
6	36200176	Plate, Valve	1	25	47050554	Guide, Plunger	3	44	90270500	Packing	28, 69
7	94737600	Spring	1	26	47030001	Rod, Connecting	3	45	47100051	Ring, Head, M20	7, 28
8	36200251	Guide, Valve	1	27	99191200	Screw, M6 x 30	5	46	47216970	Intermed. Ring	28, 71
9	90384700	O-Ring, .797 x .103	4, 5	28	47160122	Cover, Crankcase	1	47	90270400	Restop Ring	28, 69, 71
10	98222000	Cap	4	29	97596800	Oil Indicator	1	48	47200074	Pump Feet	2
11	36703201	Valve Assembly	1	30	98204100	Cap	1	49	99364400	Screw, M10 x 18	4
12	99303900	Screw, M8 x 16	8	31	90358500	O-Ring, .426 x .070	6	50	96710600	Washer, M10.2	4
13	47150122	Cover, Crankcase	1	32	99309900	Screw, M8 x 35	6	51	98217600	Cap	1
14	90391300	O-Ring, 2.675 x .103	2	33	96701400	Washer, M8.4	6	52	96751400	Washer, M21.5	1
15	640047	Bearing, Roller	2	34	96728600	Washer, M14	6	53	98210000	Cap	1
16	90162500	Seal, Oil	2	35	47040409	Plunger, (20 mm)	3	54	96738000	Washer, M17.5	1
17	90912600	Bushing	3	36	90506700	Ring, Back-up	6	55	90271000	Seal, Low Press., 20mm	28, 69
18	47010522	Crankcase	1	37	96728000	Washer	6				
19	98210600	Oil Dip Stick	1	38	47219566	Screw, Plunger	6				

**REPAIR KITS**

KIT NO.	1	2	3	4	5	6	7	10	28	69	71
ITEM NO.s INCLUDED IN KIT	4, 5 6, 7, 8 (11)	16	41	9, 10	9, 10	31, 34, 36, 37, 38	45	42, 43	42, 43, 44, 45, 46, 47, 56	44, 47, 56	46, 47
NUMBER OF ASSEMBLIES IN KIT	6	3	2	6	6	3	6	3	1	3	3
NUMBER OF CYLINDERS KIT WILL SERVICE	3	3	-	3	3	3	3	3	1	3	3

**TORQUE SPECS\***

Position	Ft.-lbs.
2	22.1
10	73.7
12	14.7
27	7.3
29	13.2
30	14.7
32	14.7
38	14.7
49	29.4
51	29.4
53	29.4

\*Decrease torque by 20% if threads are lubricated.