

Evolution EP Series From General Pump

Our Mission

To be the best fluid control device company worldwide, providing our customers with superior and innovative products, coupled with a level of service that exceeds customer expectations.

At General Pump, "We'll Find A Way!"



SOLID SHAFT				
MODEL	FLOW	PRESSURE	RPM	EBHP
EP1510S17	2.4 GPM	3,045 PSI	1750	5.0
EP1512S17	2.9 GPM	3,045 PSI	1750	6.0
EP1513S17	3.2 GPM	3,045 PSI	1750	6.6
EP1810S17	3.4 GPM	2,500 PSI	1750	5.8
EP1811S17	3.7 GPM	2,500 PSI	1750	6.3
EP1812S17	4.0 GPM	2,500 PSI	1750	6.8
EP1813S17	4.2 GPM	2,900 PSI	1750	8.3
EP1313S17	2.4 GPM	4,000 PSI	1750	6.5
EP1505S34	2.1 GPM	3,045 PSI	3400	4.4
EP1506S34	2.9 GPM	3,045 PSI	3400	6.0
EP1508S34	3.4 GPM	3,045 PSI	3400	7.1
EP1510S34	4.2 GPM	3,045 PSI	3400	8.8
EP1306S34	2.1 GPM	4,000 PSI	3400	5.8
EP1308S34	2.6 GPM	4,000 PSI	3400	7.1
EP1310S34	3.2 GPM	4,000 PSI	3400	8.8
EP1311S34	3.4 GPM	4,000 PSI	3400	9.3
EP1313S34	4.0 GPM	4,000 PSI	3400	10.9

HOLLOW SHAFT - FLANGED FOR ELECTRIC				
MODEL	FLOW	PRESSURE	RPM	EBHP
EP1510E17	2.4 GPM	3,045 PSI	1750	5.0
EP1512E17	2.9 GPM	3,045 PSI	1750	6.0
EP1810E17	3.4 GPM	2,500 PSI	1750	5.8
EP1811E17	3.7 GPM	2,500 PSI	1750	6.3
EP1812E17	4.0 GPM	2,500 PSI	1750	6.8

1" HOLLOW SHAFT- FLANGED FOR GAS				
MODEL	FLOW	PRESSURE	RPM	HP
EP1506G8	2.9 GPM	3,045 PSI	3400	6.0
EP1508G8	3.4 GPM	3,045 PSI	3400	7.1
EP1509G8	3.7 GPM	3,000 PSI	3400	7.6
EP1510G8	4.2 GPM	3,000 PSI	3400	8.8
EP1306G8	2.1 GPM	4,000 PSI	3400	5.8
EP1308G8	2.6 GPM	4,000 PSI	3400	7.1
EP1309G8	2.9 GPM	4,000 PSI	3400	7.9
EP1310G8	3.2 GPM	4,000 PSI	3400	8.8
EP1311G8	3.4 GPM	4,000 PSI	3400	9.3
EP1313G8	4.0 GPM	4,000 PSI	3400	10.9

3/4" HOLLOW SHAFT- FLANGED FOR GAS				
MODEL	FLOW	PRESSURE	RPM	HP
EP1505G6	2.1 GPM	3,045 PSI	3400	4.4
EP1506G6	2.9 GPM	3,045 PSI	3400	6.0
EP1508G6	3.4 GPM	3,045 PSI	3400	7.1

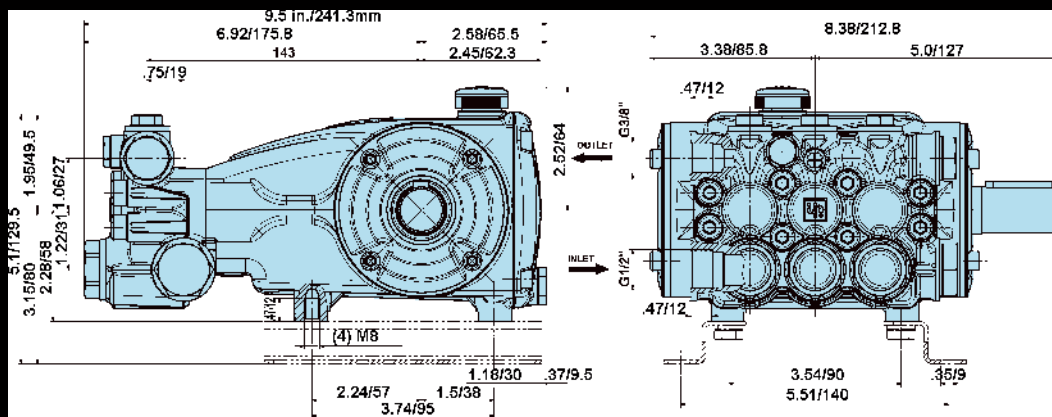

EVOLUTION EP SERIES

ISO 9001:2008 CERTIFIED



The
Big
Evolution



GP Companies, Inc.
1174 Northland Drive
Mendota Heights, MN 55120 USA
Phone: 651.454.6500 • Fax: 651.454.8015
Toll Free: 888.474.5487
www.generalpump.com
email: sales@gpcompanies.com

© GP Companies, Inc.
2016 Rev. C



General Pump is part of
the Interpump Group

Distributed By



EVOLUTION EP SERIES

NEW DUAL LIP OIL SEAL!
Better oil/water sealing



NEW CRANKCASE DESIGN!
The oversized mechanical section reduces oil temperature

Increased sliding surface of the plunger guide means better stability of the guide and reduced wear



Large diameter of sight glass means easier oil checking

Oil dipstick with breather

NEW DESIGN! Oversized Connecting rods reduce specific pressure and better lubrication



Large oil capacity means better cooling and lubrication

NEW GUIDING SYSTEM!
Optimal sliding of the plunger guide assembly reduces friction between plunger and seals extends life of seals (*Patent Pending*)

NEW OPTIMIZED OUTLET VALVES!
Better volumetric efficiency

NEW OPTIMIZED OUTLET VALVES!
Better volumetric efficiency

Inlet valves interchangeable with 63 and 44 Series

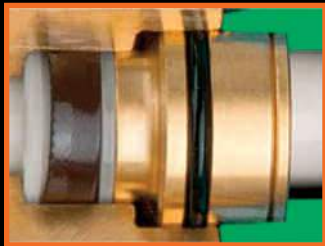

NEW! Special plunger guide bushing (*Patent Pending*)

NEW PLUNGER FASTENING SYSTEM!
Eliminates the risk of pressure build-up inside the plunger.



NEW FORGED BRASS MANIFOLD!
Working pressure increased to 4,000 PSI

Oversized premium bearing

NEW DUAL DIAMETER PLUNGER GUIDE!
Rolled oil seal sliding surface reduces risk of oil leaks and extends oil seal life



Oversized forged crankshaft

Oversized crankshaft key

NEW! Dust protection chamber between crankcase and manifold

NEW! Solid ceramic plungers with dual guide system (*patent pending*)



These Pumps are 100% Made in Italy

These Pumps are 100% Made in Italy