

SH40004HH PARTS MANUAL

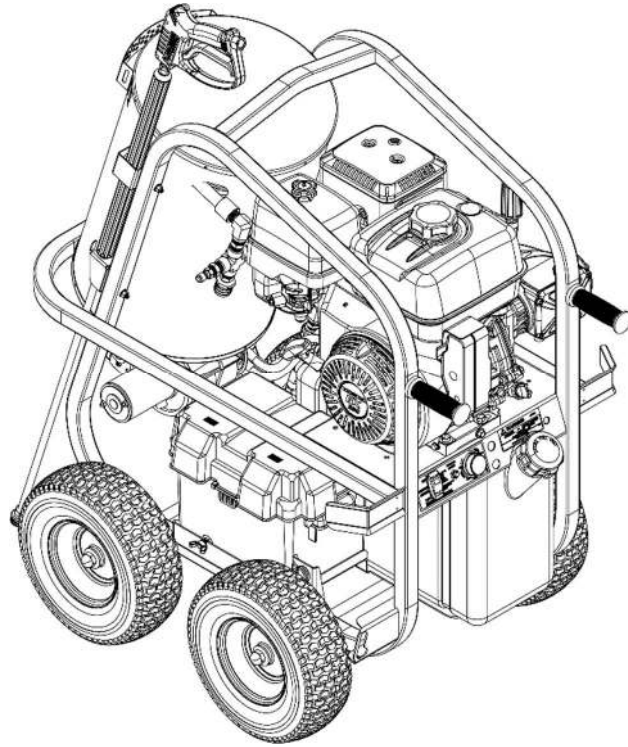

REV 1.0 BEGINNING SERIAL NUMBER 201704322

TABLE OF CONTENTS

SERVICE WARNINGS.....PG 3

PARTS BREAKDOWN

MACHINE.....PG 8

COIL BREAKDOWN.....PG 10

GUN BREAKDOWN.....PG 12

PUMP BREAKDOWN.....PG 13

BURNER HEAD BREAKDOWN.....PG 15

WIRING DIAGRAMS.....PG 16

WARNING

Breathing diesel exhaust exposes you to chemicals known to the State of California to cause cancer and birth defects or other reproductive harm.

- Always start and operate the engine in a well-ventilated area.
- If in an enclosed area, vent the exhaust to the outside.
- Do not modify or tamper with the exhaust system.
- Do not idle the engine except as necessary.

For more information go to www.P65warnings.ca.gov/diesel.

ADVERTENCIA

Respirar los gases del escape de motores a diésel le expone a químicos conocidos por el Estado de California como causantes de cáncer y defectos de nacimiento u otros daños reproductivos.

- Siempre encienda y opere el motor en un área bien ventilada.
- Si es en un área cerrada, ventile el orificio del escape hacia el exterior.
- No modifique ni altere el sistema de escape.
- No encienda el motor, excepto cuando sea necesario.

Para mayor información visite www.P65warnings.ca.gov/diesel.



EXTREMELY HAZARDOUS OR DANGEROUS SITUATION THAT WILL RESULT IN DEATH OR SERIOUS INJURY IF NOT OBEYED OR AVOIDED.

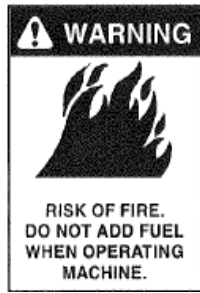

DO NOT FILL OR REFILL THE ENGINE WITH FUEL WHILE THE ENGINE IS RUNNING. STOP THE ENGINE, RELEASE THE PRESSURE IN THE HOSE AND ALLOW THE ENGINE TO COOL FOR AT LEAST 5 MINUTES BEFORE REFUELING.

DO NOT SMOKE WHEN REFILLING ANY FUEL TANKS.

DO NOT REFUEL INDOORS.

REFILL ONLY IN A WELL-VENTILATED AREA.

DO NOT OVER FILL TANKS. REFILL TANKS SLOWLY TO AVOID SPILLING FUEL.

DO NOT RESTART MACHINE UNTILL ALL FUEL SPILLS HAVE BEEN THOROUGHLY CLEANED UP AND ANY RESIDUAL FUEL HAS EVAPORATED.

DO NOT STORE THE MACHINE NEAR OPEN FLAME, HEAT SOURCE OR ANY DEVICE THAT COULD CREATE A SPARK.



DO NOT SPRAY FLAMMABLE LIQUIDS.

DO NOT OPERATE PRESSURE WASHER IN THE PRESENCE OF FLAMMABLE LIQUIDS, VAPORS, GASSES, COMBUSTIBLE DUST OR ANY OTHER COMBUSTIBLE MATERIALS.

DO NOT USE CRANKCASE OR WASTE OIL.

DO NOT PUT GASOLINE IN ANY TANK INTENDED FOR FUEL OIL.

USE ONLY No.1 OR No.2 HEATING OIL OR DIESEL FUEL IN THE BURNER TANK.

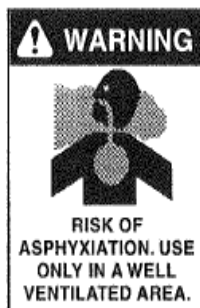

DO NOT OPERATE PRESSURE WASHER IN AN ENCLOSED AREA.

USE ONLY IN A WELL-VENTILATED AREA. PROPER VENTILATION AND OXYGEN SUPPLY IS NEED TO SUSTAIN YOUR LIFE AND FOR THE SAFE AND EFFICIENT OPERATION OF THIS MACHINE.

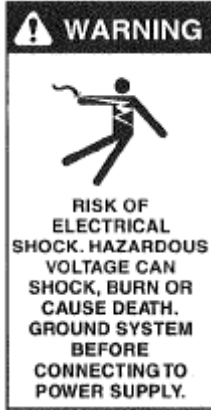

DO NOT DIRECT THE WATER STREAM OR SPRAY AT ANY ELECTRICAL INSTALLATION OF ANY KIND INCLUDING LIGHTS.
DO NOT USE THE WATER STREAM TO CLEAN THE PRESSURE WASHER.
DO NOT USE EXTENSION CORDS. USE ADDITIONAL HOSES.
DO NOT USE THE PRESSURE WASHER IF THE GFCI, CIRCUIT BREAKER OR THERMAL OVERLOAD PROTECTOR TRIPS.
DO NOT USE WHILE RAINING.

DO NOT USE IF POWER SUPPLY CORD IS DAMAGED.

DO NOT REPAIR POWER SUPPLY CORD. REPLACE IT.

DO NOT ALLOW POWER CORD TO LAY IN STANDING WATER.

USE ONLY FACTORY SUPPLIED CORD SET WITH A PROPERLY GROUNDED RECEPTACLE THAT IS EQUIPPED WITH A GROUND FAULT CIRCUIT INTERRUPTER.

USE ONLY A PROPERLY SIZED AND ISOLATED ELECTRICAL SUPPLY CAPABLE OF THE FULL LOAD AMPERAGE THAT THE PRESSURE WASHER REQUIRES.



DO NOT USE THE PRESSURE WASHER WHILE STANDING ON A LADDER OR SCAFFOLDING.
DO NOT USE WHILE STANDING ON PITCHED ROOFS.
WET SURFACE IS SLIPPERY. DANGER OF SLIP AND FALL.



DO NOT POINT THE WATER STREAM AT ANY PERSONS OR ANIMALS.
DO NOT OPERATE IN THE VICINITY OF CHILDREN.
DO NOT USE THE WATER STREAM TO CLEAN ANY PROTECTIVE CLOTHING OR BOOTS.



USE ONLY FACTORY APPROVED IDENTICAL REPLACEMENT PARTS.
DO NOT CHANGE OR TAMPER WITH FACTORY PRESET ADJUSTMENTS.



DO NOT OPERATE THE UNIT WITH A MALFUNCTIONING BURNER OR BURNER CONTROL. INSPECT BURNER AND BURNER CONTROL OPERATION BEFORE EACH USE. FAILURE TO DO SO MAY

RESULT IN AN EXPLOSION OR FIRE. IF YOU SUSPECT A PROBLEM WITH THE BURNER, DISCONTINUE USE IMMEDIATELY AND CONTACT YOUR LOCAL AUTHORIZED DISTRIBUTOR.

WARNING! (Liquid Petroleum or Natural Gas Fired Units)

FOR YOUR OWN SAFETY, IF YOU SMELL GAS:

- 1. OPEN WINDOWS.**
- 2. DO NOT TOUCH ELECTRICAL SWITCHES.**
- 3. TURN OFF BREAKER SWITCH SUPPLYING POWER TO UNIT. CLOSE GAS SUPPLY VALVE TO UNIT.**
- 4. EXTINGUISH ANY OPEN FLAME.**
- 5. IMMEDIATELY EVACUATE PREMISES AND CALL YOUR GAS SUPPLIER.**
- 6. MACHINES CAN CAUSE AN EXPLOSION WHEN OPERATED NEAR FLAMMABLE MATERIALS AND VAPORS. DO NOT-USE THIS MACHINE WITH OR NEAR FUELS, GRAIN DUST, SOLVENTS, THINNERS OR OTHER FLAMMABLE MATERIALS.**
- 7. THIS UNIT MUST BE INSTALLED IN COMPLIANCE WITH ALL APPLICABLE GAS CODES. FAILURE TO DO SO COULD RESULT IN INJURY OR DEATH TO YOU OR TO OTHER PERSONNEL.**
- 8. USE NO. 1 OR NO. 2 FUEL OIL ONLY IN OIL FIRED MACHINES. NEVER INTRODUCE GASOLINE TO THE FUEL OR OIL TANK. DOING SO COULD RESULT IN AN EXPLOSION OR FIRE. KEEP THE PROPER FUEL IN THE PROPER TANK.**



POTENTIALLY HAZARDOUS SITUATION THAT COULD RESULT IN DEATH OR SERIOUS INJURY IF NOT OBEYED OR AVOIDED.

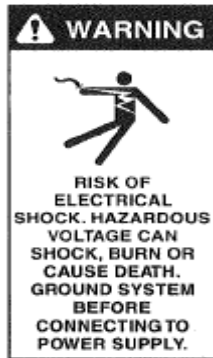

DISCONNECT POWER BEFORE SERVICING THE PRESSURE WASHER.

DISCONNECT SPARK PLUG BEFORE SERVICING THE PRESSURE WASHER.

DO NOT DIRECT THE WATER STREAM OR SPRAY AT ANY ELECTRICAL INSTALLATION OF ANY KIND INCLUDING LIGHTS.



DO NOT TOUCH HOT SURFACES. EG. MUFFLER, BURNER, ENGINE, HEAT EXCHANGER, EXHAUST HEAD.

USE ONLY INSULATED EXTENSION WAND WITH HOT WATER.

DO NOT ALLOW HOSES TO TOUCH HOT SURFACE.



DO NOT USE PRESSURE WASHER WITHOUT PROPER PROTECTIVE WEAR. USE EYE PROTECTION, RUBBER GLOVES, RUBBER BOOTS, AND PROTECTIVE CLOTHING.

DO NOT USE CORROSIVE OR AGGRESSIVE CHEMICALS WITHOUT PROPER PROTECTIVE WEAR.

USE ONLY APPROVED ACCESSORIES RATED FOR HOT WATER AND HIGH PRESSURE.



POTENTIALLY HAZARDOUS SITUATION THAT COULD RESULT IN PERSONAL INJURY OR PROPERTY DAMAGE IF NOT OBEYED OR AVOIDED.

DO NOT LEAVE THE PRESSURE WASHER RUNNING UNATTENDED. TURN THE MACHINE OFF AND RELEASE ALL PRESSURE FROM THE SYSTEM.

DO NOT DEFEAT THE TRIGGER GUN SAFETY

DO NOT LOCK THE TRIGGER IN THE OPEN POSITION IN ANY WAY.

KNOW THE MACHINE CONTROLS AND HOW TO QUICKLY SHUT DOWN AND RELEASE ALL PRESSURE IN THE SYSTEM.

DO NOT OPERATE THE MACHINE WITHOUT ALL GUARDS AND PROTECTIVE COVERS IN PLACE.

DO NOT ALLOW ANY PART OF PERSONS OR HOSES TO CONTACT HOT SURFACES.

INSPECT THE PRESSURE WASHER AND HOSES FOR DAMAGED PARTS DAILY.

DO NOT OPERATE WITH ANY FAULTY OR DAMAGED COMPONENTS.

DISCONNECT POWER CORD, BATTERY NEGATIVE AND SPARK PLUG BEFORE PERFORMING ANY SERVICE ON THE PRESSURE WASHER.

KEEP ALL HOSES AND POWER CORDS AWAY FROM VEHICLE TRAFFIC.

DO NOT MOVE THE MACHINE BY PULLING ON THE HOSE.

DO NOT DIRECT THE HIGH PRESSURE WATER STREAM AT FRAGILE OBJECTS.

DO NOT USE ANY ACCESSORIES UNLESS THEY ARE RATED AT OR ABOVE THE WORKING PRESSURE OF THE MACHINE.

ALWAYS USE EYE, FACE, HAND, FOOT, HEARING, AND BODY PROTECTIVE WEAR.

DO NOT OPERATE PRESSURE WASHER IF FATIGUED OR UNDER THE INFLUENCE OF ALCOHOL OR DRUGS. **BE ALERT AT ALL TIMES.**

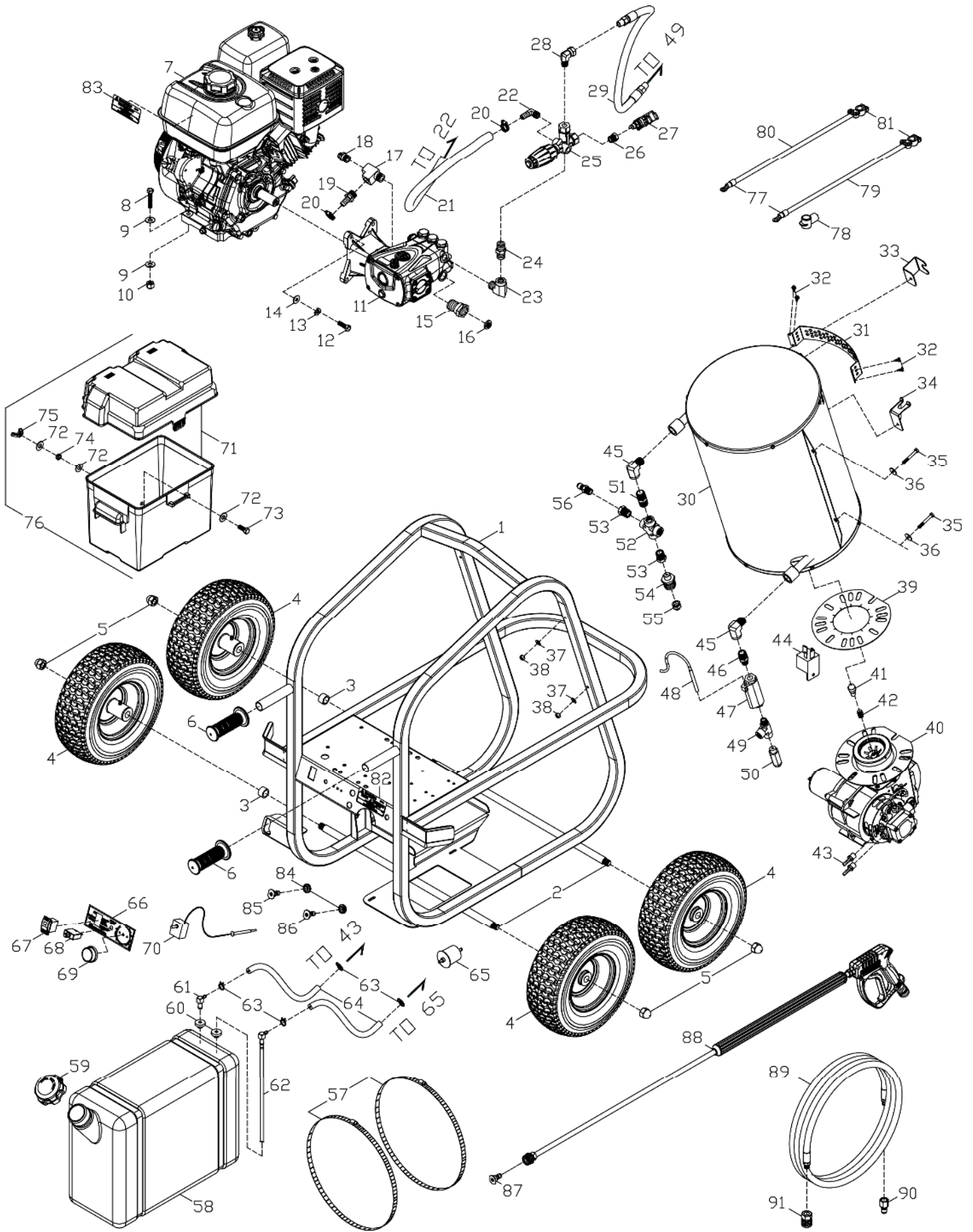

SH40040HH PARTS LIST

S/N201801570

19-Jul-18

NUMBER	PART NUMBER	DESCRIPTION	QTY.	NUMBER	PART NUMBER	DESCRIPTION	QTY.
1	HSH05	FRAME ASSEM SH RED POWDER COAT	1	48	VS003	REED SWITCH	1
2	SR625	ROD, THREADED 5/8 ZINCE PLATED	2	49	D6612	STREET TEE 3/8 STEEL	1
3	SR122	RD TUBE 1.00 x .625 SPACER	2				
4	HT127	WHEEL&TIRE TURF 13x5.00-6 3/4 BEARING	4	50	UP045	PRESSURE RELIEF 4500	1
5	FNA09	NUT ACORN 5/8-11	4	51	DB508	NIPPLE 1/2 STEEL	1
6	HL010	HAND GRIP 1in MX*	2	52	DA888	CROSS 1/2 STEEL FORGED	1
7	MH135	ENGINE 389cc HONDA E/S	1	53	DA086	BUSHING 1/2M x 3/8F	2
8	FB632	BOLT 3/8 X2 PLD	4	54	UPB05	ADAPTER FITTING BURST DISC	1
9	FWC06	WASHER CUT 3/8 PLD, USS	8	55	UPB80	BURST DISC 8000psi TORQUE 32-4	1
10	FNL06	NUT LOCK 3/8-16 PLD	4	56	DQ7MP	COUPLER 3/8 PLUG MALE GENERAL	1
				57	FC074	WORMGEAR CLAMP 2 1/2 x 13 1/4	2
11	PH354	PUMP, 3.5 @ 4000 1" DD GAS	1	58	WT075	FUEL TANK 7.5 DIESEL CLEAR*	1
12	FB620	BOLT 3/8 X1 1/4 PLD	4	59	WT080	FUEL CAP; DIESEL	1
13	FWL06	WASHER SPLIT 3/8 PLD	4	60	DFF04	FUEL TANK BUSHING 1/4"	2
14	FWC05	WASHER CUT 5/16 PLD*	4				
15	D008M	GARDEN HOSE 1/2 NPT MALE	1	61	DFE04	FUEL TANK ELL 1/4"	1
16	D0021	SCREEN WASHER GARDEN HOSE ADAPTER	1	62	DF599	FUEL TANK ADAPTER WITH PICK UP TUBE	1
17	D6588	STREET TEE 1/2 BRASS	1	63	FC104	HOSE CLAMP WIRE 1/4	4
18	UPT46	THERMAL DUMP VALVE 145F	1	64	DHP08	HOSE; 1/4 FUEL 50psi FLEXIBLE	3 FT
19	D8088	HOSE BARB 1/2 BRASS	1	65	BF015	FUEL FILTER; INLINE	1
20	FC008	WORM GEAR CLAMP 1/2	2	66	GLL63	LABEL SH CONTROL PANEL	1
				67	EC405	ROCKER SWITCH CLR 12V 20A DPST	1
21	DHC80	HOSE; 1/2 LO PRESS BLACK	2 FT	68	ECF15	CIRCUIT BREAKER 20 AMP*	1
22	D8060	HOSE BARB 90 DEG 1/2H X 3/8MPT	1	69	ECH70	KNOB; BLUE .25 x 1.50D	1
23	DC568	STREET ELL 3/8 STEEL	1	70	ECH50	THERMOSTAT; 60 - 250 70" CAP	1
24	DB506	NIPPLE 3/8" STEEL	1				
25	UU323	UNLOADER; 4500 10.5 GPM AR	1	71	HB101	BATTERY BOX, SNAP ON G24	1
26	DA064	BUSHING 3/8 X 1/4 STEEL	1	72	FWCS6	WASHER CUT 3/8 STAINLESS STEEL	3
27	VS030	PRESSURE SWITCH 1/4 PR16	1	73	FB618	BOLT 3/8 X 1 SS	1
28	DE866	SWIVEL 3/8F x 3/8M 90	1	74	FNJS6	NUT LOCK JAM 3/8-16 STAINLESS	1
29	DH034	HOSE 3/8 x 34IN 4000psi NO WIP	1	75	FNW06	WING NUT 3/8-16 STAINLESS	1
30	BC300	COIL ASM 1 PASS 4 SPIRAL ASM	1	76	HB150	SNAP ON BATTERY BOX ASM	1
				77	ET320	TERMINAL BATTERY #4 YELLOW	2
31	B0316	COIL EXHAUST DIFFUSER	1	78	ES250	PROTECTIVE BOOT; RED	1
32	FA011	SCREW #10 x 1/2 SS SELF DRILL	4	79	EW604	BATTERY CABLE #4 RED	2.7 FT
33	HSH10	WAND BRACKET 14 GA STAINLESS	1	80	EW605	BATTERY CABLE #4 BLACK	2.12 FT
34	HSH09	WAND BRACKET BOTTOM 14 GA STAINLESS	1				
35	FB432	BOLT 1/4 X2 SS	4	81	ET500	BATTERY POST TERMINAL	2
36	FWS06	WASHER 1/4 7/8od STNLS	4	82	GLL20	LABEL DIESEL FUEL ONLY	1
37	FWS04	WASHER SAE 1/4 SS 9/32 X 5/8*	4	83	GLL10	LABEL GASOLINE ONLY	1
38	FNL04	NUT LOCK 1/4-20 PLD*	4	84	HLB09	GROMMET NOZZLE HOLDER	2
39	BM035	BECKETT GASKET / UNIVERSAL	1	85	NQ352	NOZZLE/QDC 035 x 15	1
40	BU013	BURNER; BECKET 12V W/ SUPPORT	1	86	NQ354	NOZZLE/QDC 035 x 40	1
				87	NQ252	NOZZLE/QDC 025 X 25	1
41	BZ175	FUEL NOZZLE 1.75 80B	1	88	AVGH4P	WAND 48" MOLDED GRIP, GUN, QC	1
42	BZPT0	PROTEK VALVE, DELEVAN FUEL NO	1	89	DH057	HOSE 3/8 x 50' 4000 PSI	1
43	D8044	HOSE BARB 1/4 BRASS	1	90	DQ7FP	COUPLER 3/8 PLUG FEMALE	1
44	ECC05	RELAY, 12V 70 AMP	1				
45	DC588	STREET ELL 1/2" STEEL	2	91	DQ7FS	COUPLER 3/8 SOCKET FEMALE	1
46	DB507	NIPPLE 3/8" x 1/2" STEEL	1				
47	VS005	FLOW SWITCH 8 @ 4200 STS	1		ESH20	12V WIRING HARNESS SH4240HG NOT SHOWN	

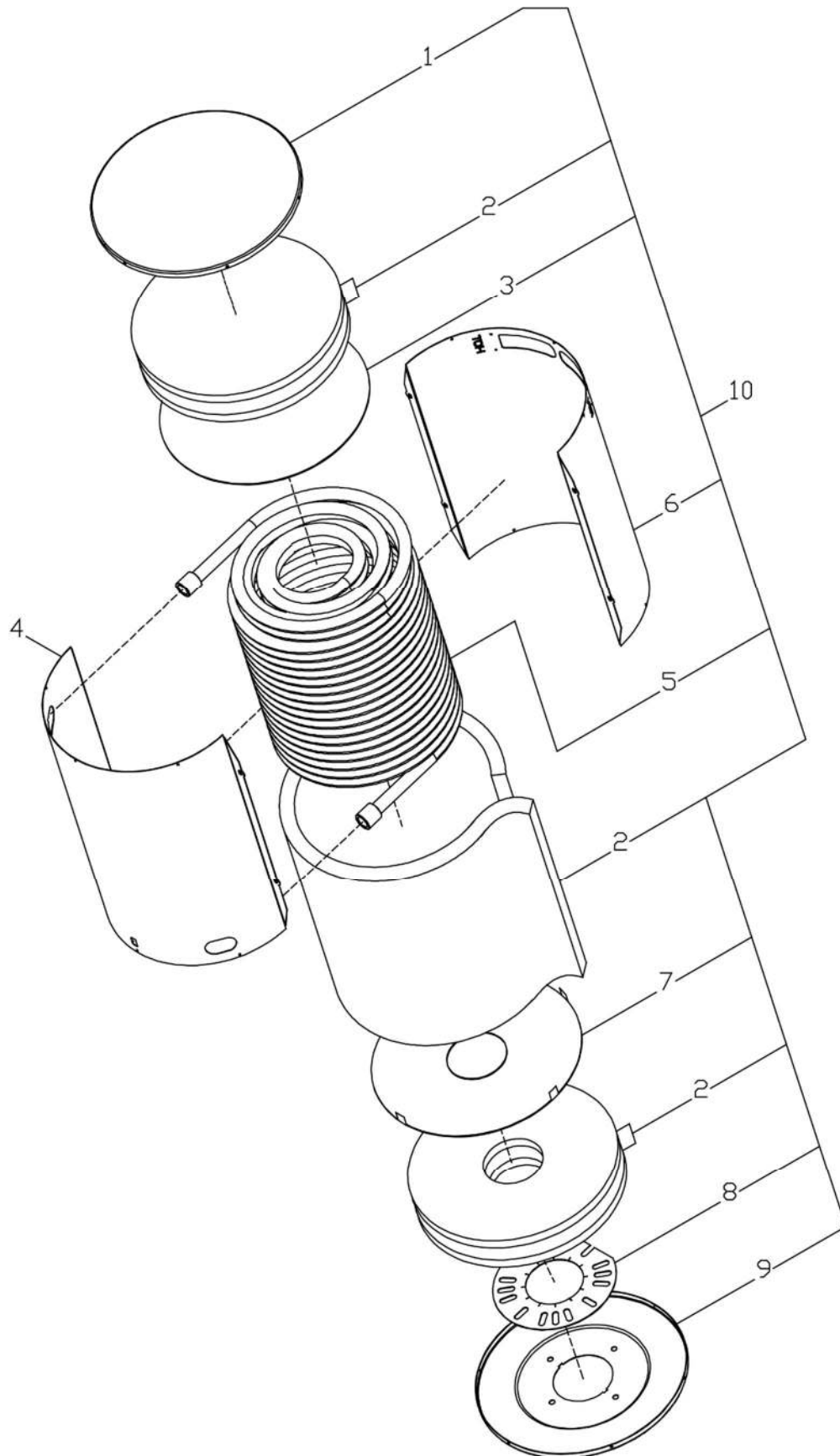

BC300 PARTS LIST

NUMBER	PART NUMBER	DESCRIPTION	QTY.
1	B0303	COIL CAP OUTLET SIDE	1
2	BN053	INSUL BLKT 50SQ' x 1/2" x 24" 8#25'	.42 ROLL
3	BN327	INSULATION DISC RETAINER	1
4	B0314	COIL WRAP BOTTOM	1
5	BC144	COIL 4 SPIRAL 1 PASS	1
6	B0313	COIL WRAP TOP	1
7	BN327	INSUL DISC RETAINER 14.0" DIA	1
8	BM035	BECKETT GASKET / UNIVERSAL	1
9	B0304	COIL CAP BURNER END	1
10	BC300	COIL ASM 1 PASS 4 SPIRAL SCH80	1

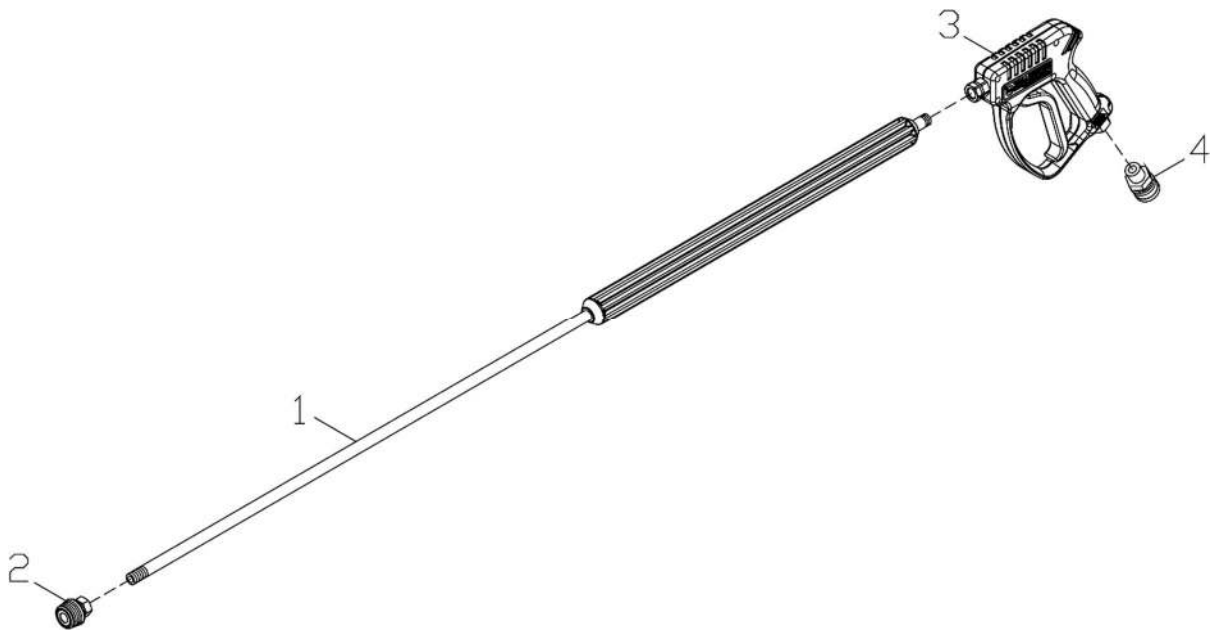

AVGH4P PARTS LIST

NUMBER	PART NUMBER	DESCRIPTION	QTY.
1	VW045	TRIGGER GUN, INSULATED 5000PSI	1
2	DQ04S	INSULATED COUPLER 1/4 SOCK FEM	1
3	VG200	TRIGGER GUN, INSULATED 5000PSI	1
4	D10004S	QC SOCKET 3/8M SS	1

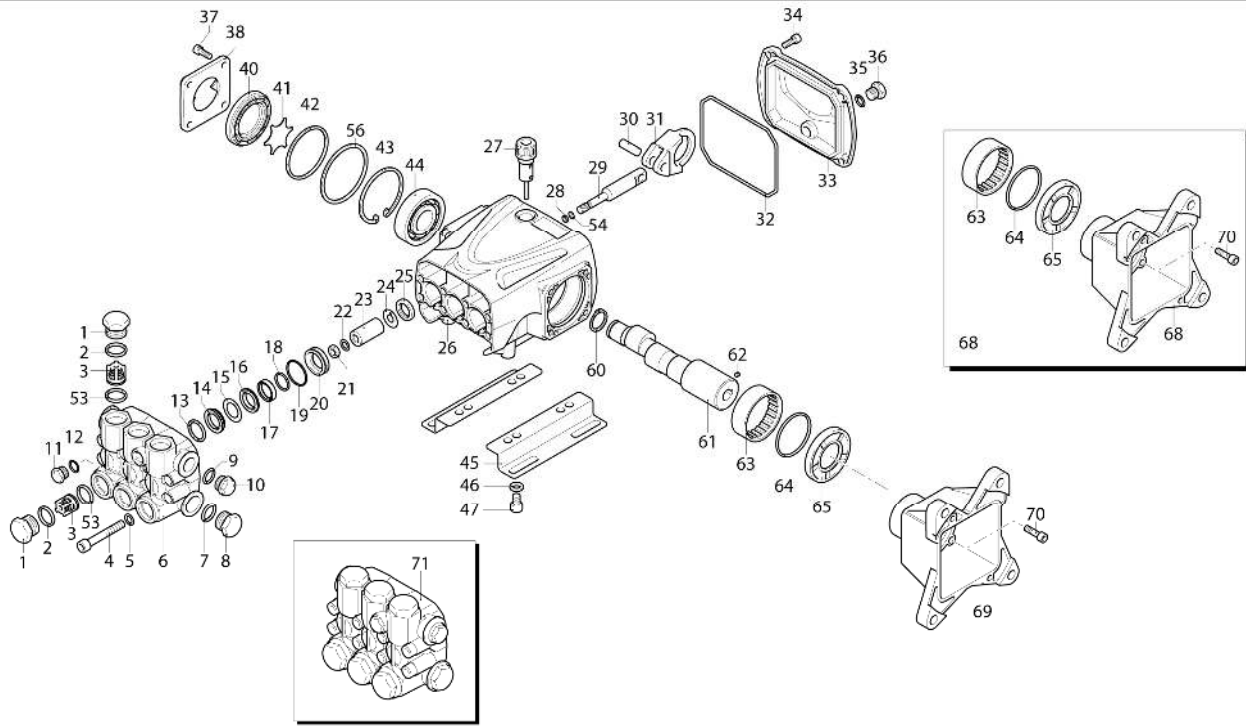

Repair Kits

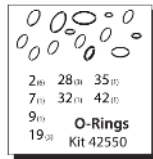
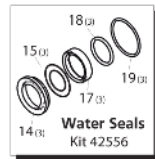

Pos	Code	Description	Qty	Pos	Code	Description	Qty	Legend		
	960090	Valve Cap	(478 in/lbs) 6	34	3200220	Screw TCEI 6x16	(71 in/lbs) 4	For ○	For ●	For ◆
	960850	Valve Cap SST	(478 in/lbs) 6	35	820510	O-Ring ø 10.82x1.78	1	RRV3G36D	RRV3.5G36D	RRV4G36D
	9600909	Valve Cap threaded 1/4" brass	(478 in/lbs) 6	36	880581	Plug 1/4" G	(133 in/lbs) 1			
	9608507	Valve Cap - threaded 1/4" SST	(478 in/lbs) 6	37	1200430	Screw M 6x16	(92 in/lbs) 4	For ■		
2	960160	O-Ring ø 17.86x2.62	6	38	3200070	Cover	1	RRV4G40D		
3	889052	Complete valve	6	40	3220080	Oil indicator	1			
4	800860	Screw M 8x55	(225 in/lbs) 8	41	3200090	Disc	1			
5	1381850	Washer	8	42	650560	O-Ring ø 56.82x2.62	1			
6	3220090	Head	1	43	200390	Snap ring	1			
7	180101	O-Ring ø 17.5x2	1	44	1981210	Bearing	1			
8	820361	Plug 1/2" G	(354 in/lbs) 1	45	3200210	Base	2			
9	740290	O-Ring ø 14x1.78	1	46	1322640	Washer	4			
10	1980740	Plug 3/8" G	(221 in/lbs) 1	47	850250	Screw M 8x12	4			
11	880581	Plug 1/4" G	(133 in/lbs) 1	53	880830	O-Ring ø 15.54x2.62	6			
12	820510	O-Ring ø 10.82x1.78	1	54	1080550	Ring	3			
13	2760220	Ring	3	56	3220780	O-Ring ø 61.8x0.5	1			
14	1342761	Gasket	3	60	1260770	Circlip	1			
15	3200680	Ring	3	61	3220240	Crankshaft - Hollow Shaft	◆ 1			
16	3220150	Piston guide	3	3220450	Crankshaft - Hollow Shaft	● 1				
17	3200690	Gasket	3	3220460	Crankshaft - Hollow Shaft	○ 1				
18	3200700	Ring	3	62	820440	Grub screw M 6x6	1			
19	770260	O-Ring ø 23.52x1.78	3	63	3220260	Bearing	1			
20	3220140	Piston guide	3	64	3220430	O-Ring ø 56.87x1.78	1			
21	1260110	Nut M 8	(106 in/lbs) 3	65	3220270	Oil Seal	1			
22	1260100	Washer	3	66	780060	Screw M 6x25	(92 in/lbs) 4			
23	1780070	Piston	3	68	32202650-1	Flange assembly	1			
24	1260091	Spacer	3	69	3220250	Flange	1			
25	1260460	Ring	3	70	780330	Screw M 6x20	(92 in/lbs) 4			
26	3220010	Pump body	1	71	42638	Complete head assembly	◆●○ 1			
27	880130	Plug	(44 in/lbs) 1		3229203	Complete head assembly	■ 1			
28	480480	O-Ring ø 4.48x1.78	3		AR64516	Oil	2			
29	3220060	Piston	3			OIL CAPACITY - 13.35OZ				
30	3220070	Conrod pin	3							
31	3220040	Conrod	3							
32	651540	O-Ring ø 107.62x2.62	1							
33	3220030	Rear cover	1							

RRV3.5G40HD-F24
1" Hollow Shaft - Gas

SPECIFICATIONS

Pump Model	RRV3.5G40HD-F24
Maximum Volume	3.5 GPM
Maximum Discharge Pressure	4,000 PSI
Maximum Pump Speed	3400 RPM
Maximum Inlet Pressure	125 PSI
Maximum Inlet Volume	Flooded
Plunger Bore	15 mm
Plunger Stroke	8.2 mm
Oil Capacity	13.35 oz.
Maximum Fluid Temperature	140° F
Inlet Port Thread	1/2"-14 BSP-F
Discharge Port Thread	3/8"-19 BSP-M
Shaft Diameter	Hollow, 1"
Weight	18.0 lbs.
Dimensions	2268 mm X 241 mm X 152 mm

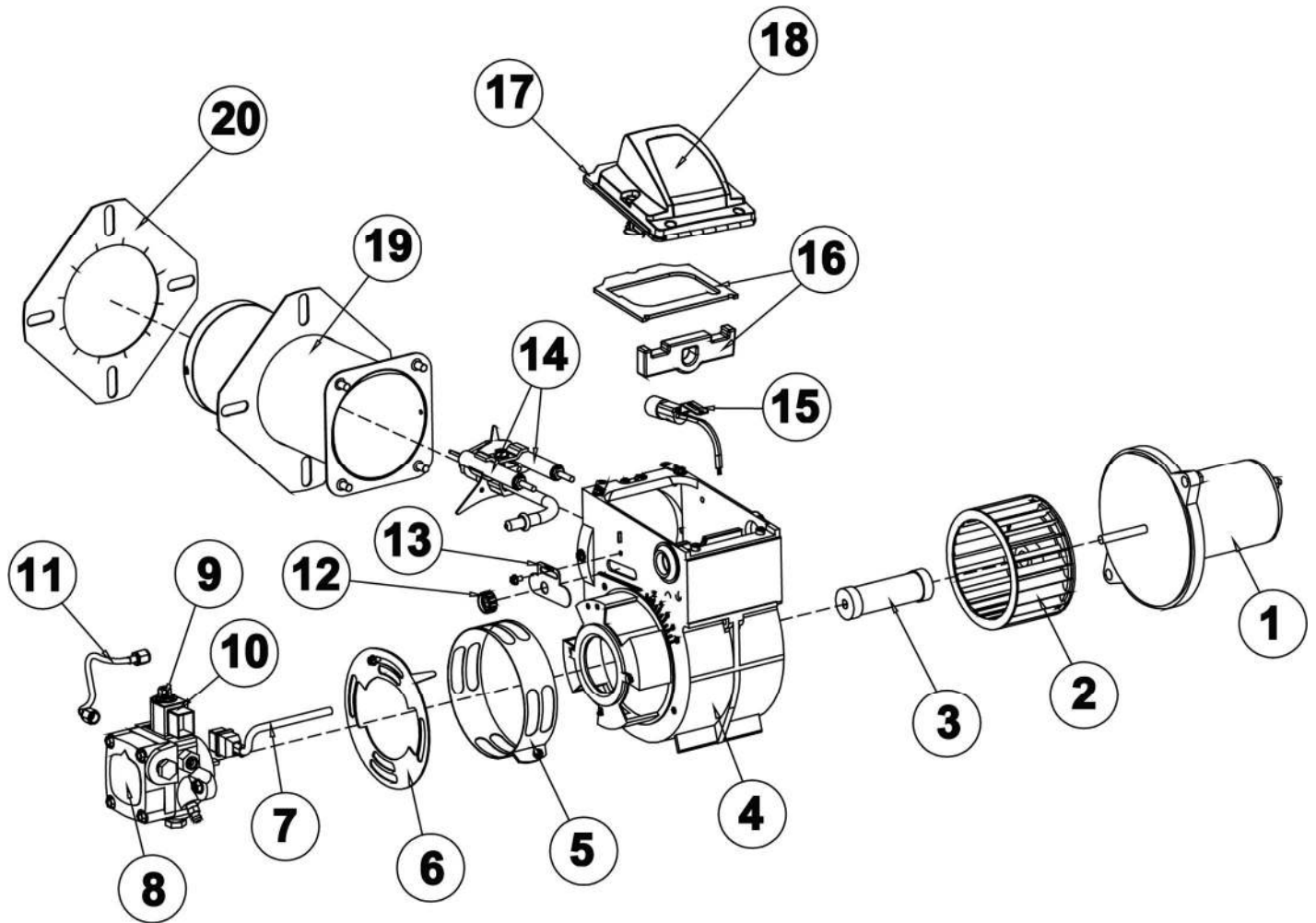

BU013 PARTS LIST

NUMBER	PART NUMBER	DESCRIPTION	QTY.	NUMBER	PART NUMBER	DESCRIPTION	QTY.
1	52145U	DC MOTOR	1	11	5394	8" COPPER TUBING	1
2	21404U	BLOWER WHEEL	1	12	3666	ESCUTCHEON PLATE SPLINE NUT	1
3	21405	COUPLING	1	13	3493	ESCUTCHEON PLATE	1
4	55874BKU	BURNER HOUSING BLACK	1	14	570731	ELECTRODE KIT OVER 3-5/8"	1
5	5151501	AIR BAND	1	15	7492/7006U	CAD EYE CELL DETECTOR	1
6	3494	AIR SHUTTER	1	16	51411	IGNITER GASKET KIT	1
7	21807	CORD SET	1	17	5218301U	IGNITER ASSY WITH BASEPLATE	1
8	2184402U	PUMP CLEAN CUT	1	18	5218305U	IGNITER ONLY	1
9	21877U	VALVE STEM	1	19	SPECIFY	AIR TUBE ASSY	1
10	21754U	12 VOLT COIL	1	20	3616U	FLANGE MOUNTING GASKET	1

HONDA GX390 WIRING DIAGRAM

ELECTRIC START TYPES WITH OIL ALERT AND 10 AMP CHARGE SYSTEM

Bl	Black	Br	Brown
Y	Yellow	O	Orange
Bu	Blue	Lb	Light blue
G	Green	Lg	Light green
R	Red	P	Pink
W	White	Gr	Gray

TWO COLORED WIRE (EXAMPLE: YELLOW/RED)

